

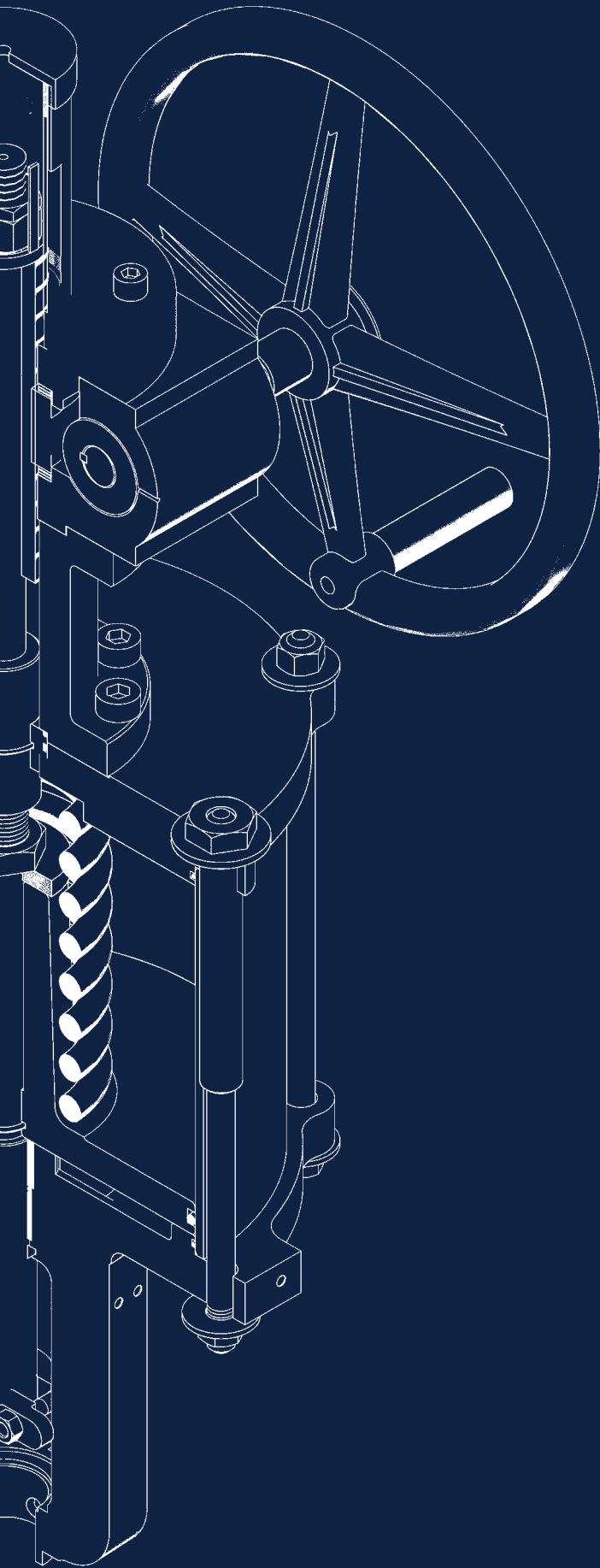

# P-Series Linear Spring Cylinder Actuator



It all flows from expertise.



# Contents

P-Series Linear Spring Cylinder Actuator overview	01
Design features & performance benefits	02
Engineering data	02
Component list and materials of construction	04
Principles of operation	05
Air fail action	06
Improving actuator stroking speeds	07
Hand wheel operators	08
Standard dimensions & weights	09

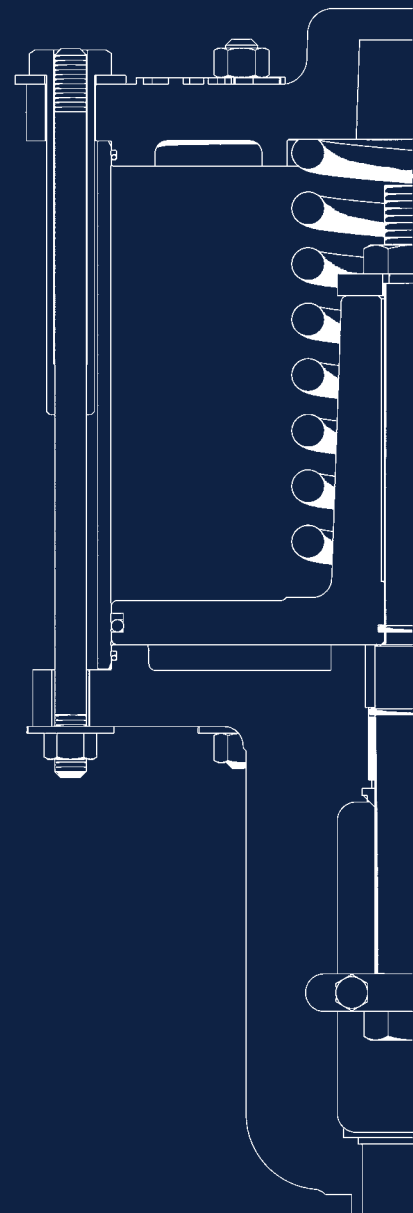

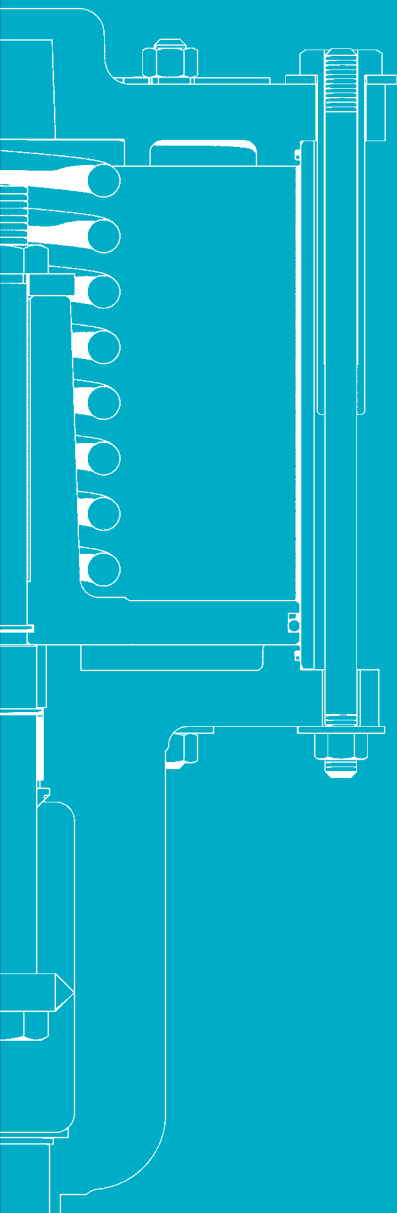

# P-SERIES ACTUATOR

Designed for fitting onto a wide range of control valves, louvres or dampers, these high power actuating units are for use in on/off, or modulating service with increased thrust capacity compared to diaphragm actuators.

Available as either a single acting or double acting unit. The design is field reversible and utilizes a wide range of springs to provide positive fail action. Positioners are normally yoke mounted and of the double-acting type providing air to both sides of the piston and giving a robust and precise unit that is resistant to load fluctuations.

## Design features

- ✔ High thrust capability capable of using air supplies up to 150psig (10bar)
- ✔ Multi-size options with long stroke capability
- ✔ Robust components for trouble free, low cost ownership
- ✔ Positive spring air fail action, which is field reversible
- ✔ Lightweight corrosion resistant construction
- ✔ Rotary options available

## Performance benefits

- ✔ High degree of stem positioning accuracy
- ✔ Cylinder design has lower air consumption than a comparable diaphragm actuator
- ✔ Highly stable providing inherent stiffness over full stroke
- ✔ Highly responsive with minimum latency on movement or positioning
- ✔ High resolution of stem positioning for up to 12in strokes as standard with longer strokes available
- ✔ Adjustable actuating forces to suit different applications
- ✔ Rigorous in-field testing
- ✔ Manufactured to ISO 9001 certification

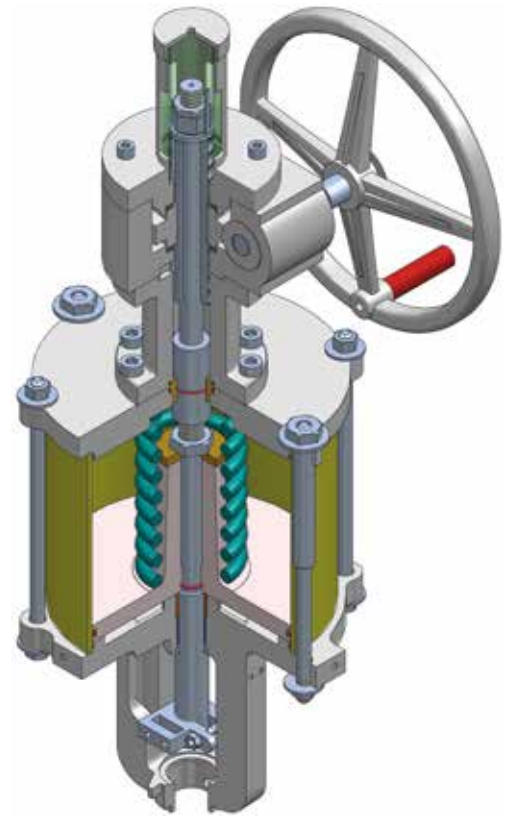

P-Series Linear  
Spring Cylinder Actuator

## Engineering data

A range of compact, highly effective and reliable high-thrust pneumatic actuators, the Severn P-Series is capable of working in the most punishing environments. Designed for use in on/off or modulating applications, they are capable of working up to 150psig (10bar) pressure.

An internal spring allows for positive air fail action and the actuator is fully field reversible without any additional parts. The fitting of a yoke mounted double-acting positioner allows air to be fed to both sides of the piston, providing exceptionally stiff, precise movement, together with very high frequency response. This is of particular benefit to provide control where line pressure fluctuations are an issue.

## Engineering data (continued)

### Ambient operating temperature

For standard materials: -20 °C to +80 °C.

For special materials: -55 °C to +100 °C.

For other operating temperatures please contact us.

### Actuator sizes

The range includes six standard sizes: 25, 50, 100, 200, 315 and 380in<sup>2</sup> (nominal piston area). Please contact us for more information on oversized actuators up to 600in<sup>2</sup>.

### Actuator strokes

The range includes short stroke and long stroke actuators.

### Hand wheels

A range of geared handwheels for top or underside cylinder mounting is available.

### Positioner input signals

Using yoke mounted external positioners, normally double acting type, 3-15psig (0.2-1.0bar), 4-20, digital. Also spilt ranges of the above signals. Digital "Smart" positioners are available. A wide range of positioners are available to suit customer requirements.

### Pneumatic supply pressure

Minimum 5psig (0.33bar) above calculated actuator requirement. Maximum to actuator is 150psig (10bar).

### Operating supply gases

Air, nitrogen and oxygen. Options: methane (natural gas) filter regulator recommended to ensure clean supply.

### Air fail action

Positive air fail action from internally mounted springs. Action is field reversible without additional parts.

### Actuator mean thrust capability

Supply Pressure 150psig (10bar).

Actuator Size	Net thrust	
	lbF	kN
P25S	4945	21.9
P50S	8315	36.9
P100L	20577	91.5
P200S	34163	151.9
P315	50302	223.7
P380	60330	268.3

### Hysteresis and linearity

Within +/- 2%.

### Speed and sensitivity

Signal change of 0.01psig (0.013mA) reverses.

**Table 1: P-Series Linear Spring Cylinder Actuator – Cylinder and stem size details**

Actuator dimensions					Effective area of cylinders				Stem dimensions				Maximum volume over piston
Cylinder	Stroke		Bore diameter		Upper area		Lower area		Stem diameter		Stem area		
Size	in	cm	in	cm	in <sup>2</sup>	cm <sup>2</sup>	in <sup>2</sup>	cm <sup>2</sup>	ins	cm	in <sup>2</sup>	cm <sup>2</sup>	in <sup>3</sup>
25	0.75	20	6	15.2	28.3	182	27.8	179	0.75	1.90	0.44	2.80	105
<b>25B</b>	4.0	100	6	15.2	28.3	182	27.8	179	1.38	3.50	1.48	9.70	185
50	1.5	40	8	20.3	50.3	325	49	316	1.25	3.17	1.23	7.70	295
<b>50B</b>	2.5	63	8	20.3	50.3	325	49	316	1.38	3.50	1.48	9.70	550
100	2.5	63	12	30.5	113.1	729	111.3	718	1.5	3.81	1.76	11.60	930
100-5	5.0	125	12	30.5	113.1	729	111.3	718	1.5	3.81	1.76	11.60	1320
100-6	6	150	12	30.5	113.1	729	111.3	718	1.5	3.81	1.76	11.60	1820
100-12	12	300	12	30.5	113.1	729	111.3	718	1.5	3.81	1.76	11.60	1820
<b>100B</b>	4.0	100	12	30.5	113.1	729	111.3	718	1.5	3.81	1.76	11.60	1120
200-5	5.0	125	16	40.6	197	1271	195	1258	2.25	5.72	3.98	25.70	3340
200-6	6.0	150	16	40.6	197	1271	195	1258	2.25	5.72	3.98	25.70	3340
200-12	12.0	300	16	40.6	197	1271	195	1258	2.25	5.72	3.98	25.70	4740
<b>200B</b>	5.0	125	16	40.6	197	1271	195	1258	2.25	5.72	3.98	25.70	3340
315-12	12	30.5	20	50.8	314.2	2027.1	30.59	197.4	2.25	5.715	3.98	25.7	7886
380-6	6	15.2	22	55.9	380.1	2452.3	376.2	2427.1	2.25	5.715	3.98	25.7	6983
450-9	9	22.9	24	61.0	452.4	2918.7	444.1	2865.2	3.25	8.255	8.3	53.5	9974
635-9	9	22.9	28.5	72.4	637.9	4115.5	625.4	4034.8	4	10.16	12.57	81.1	5952

Note: **Suffix B** denotes baseplate actuators used to operate butterfly valves or similar and are not normally used to operate globe or angle control valves.

# Component list and materials of construction

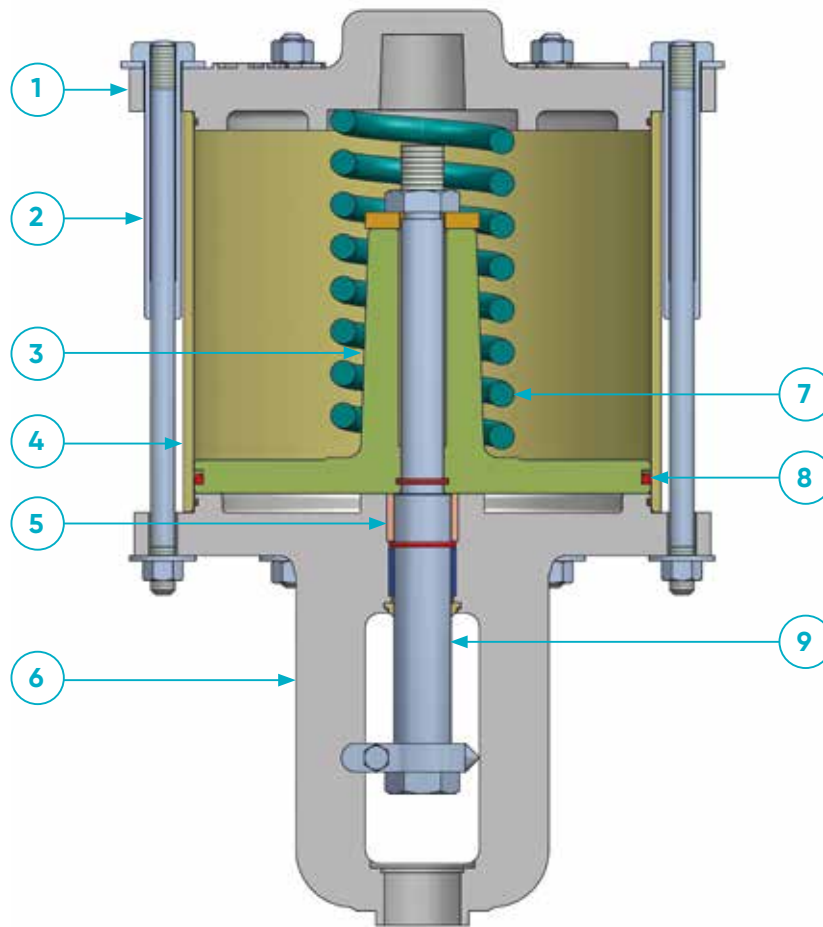

Key No.	Component	Materials of construction					
		Standard Configuration	Option 1 Low Temp	Option 2 STAINLESS	Option 3 C STEEL CYL / NO AL	Option 4 Stainless Steel - Tie rods	Option 5 Ally T.C & BP
1	Top Cap	Carbon Steel	ASTM A350 LF2	Stainless Steel	Carbon Steel	Carbon Steel	Aluminium
2	Tie Rods	Carbon Steel - Hot Dip Galvanizing	316 Fastener grade A4-70	316 Fastener grade A4-70	Carbon Steel - Hot Dip Galvanizing	316 Fastener Grade A4-70	316 Fastener Grade A4-70
3	Piston	Aluminium	Aluminium	Aluminium	Aluminium	Aluminium	Aluminium
4	Cylinder	Carbon Steel	Stainless Steel	Stainless Steel	Carbon Steel	Carbon Steel	Black Amalgon
5	Guide Bush	Leaded Bronze Casting, LG2	Leaded Bronze Casting, LG2	Leaded Bronze Casting, LG2	Leaded Bronze Casting, LG2	Leaded Bronze Casting, LG2	Continuous Cast Bronze BS 1400 LG2
6	Yoke & Base Plate	Carbon Steel	ASTM A352 LCB/LCC	Stainless Steel	Carbon Steel	Carbon Steel	Aluminium
7	Springs	Spring Steel, 50CrV4/ 51CrV4(1)	17-7 PH Spring(1)	17-7 PH Spring(1)	Spring Steel, 50CrV4/ 51CrV4(1)	Spring Steel, 50CrV4/ 51CrV4(1)	Spring Steel, 50CrV4/ 51CrV4(1)
8	O Ring (Piston)	Nitrile	Silicone	Silicone	Nitrile	Nitrile	Nitrile Rubber
9	Piston Rod	316 SS	316 SS	316 SS	316 SS	316 SS	316 SS

# Principles of operation

P-Series actuators are capable of operating as a spring-less double acting actuator if required. Offering lower combined valve heights and potentially faster operating speeds. To achieve the air fail action a spring can be utilised and the wide range available allows the actuator to provide the best performance for your application.

## Inherent actuator stiffness and stability

Actuator stiffness is defined as its ability to withstand suddenly changing dynamic forces acting on the valve trim as a result of varying process requirements. In order to be positioned accurately within the operator requirements, the actuator requires an inherent stiffness to minimise fluctuations in its position and this is achieved in the P-Series range by delivering air to both sides of the cylinder piston.

The result is a vast improvement over typical spring opposed diaphragm units in which spring rates remain the same throughout the stroke.

For example when a valve is operated close to its seat with the flow over the plug, sudden changes in the dynamic force can cause the valve to "bath-plug" and slam shut if the actuator has insufficient stiffness. For this reason flow over the plug options are to be avoided in control applications when specifying spring opposed diaphragm actuators. By contrast, P-Series products enable operation with the flow either over, or under, the valve plug with precise positioning under severe throttling conditions. Table 4 (below) shows the maximum valve seating force available for standard spring and air pressure combinations, with the P-Series Actuators built for air fail close and alternatively air fail open operation.

**Table 3: P-Series Linear Spring Cylinder Actuator – Cylinder spring data**

Cylinder dimensions				Spring to close		Spring to open	
Cylinder size	Stroke (in)	Spring design	Spring rate (lb/in)	Spring extended (lb)	Spring retracted (lb)	Spring extended (lb)	Spring retracted (lb)
25	0.75	Light	100	175	250	250	175
25	0.75	Standard	180	315	450	450	315
25	0.75	Heavy	445	778	1112	1112	778
<b>25B</b>	4.00	Standard	75	247	547	N/A	N/A
50	1.50	Standard	163	326	570	570	328
50	1.50	Medium	398	796	1393	1393	796
50	1.50	Heavy	546	1092	1911	1911	1092
<b>50B</b>	4.00	Light	200	500	1300	N/A	N/A
<b>50B</b>	4.00	Standard	200	800	1600	N/A	N/A
100	2.50	Light	373	745	1675	1675	745
100	2.50	Standard	550	1100	2475	2475	1100
100	2.50	Heavy	700	1400	3150	3150	1400
<b>100B</b>	4.00	Standard	400	800	2400	N/A	N/A
<b>100B</b>	4.00	Heavy	600	1200	3600	N/A	N/A
200	5.00	Multi-pack	260	1560	2860	2860	1560
200	5.00	Heavy	800	4800	8800	8800	4800
200	5.00	Intermediate	100	600	1100	1100	600
200	5.00	Medium	90	540	990	990	540
200	5.00	Light	70	420	770	770	420
<b>200B</b>	5.00	Multi-pack	260	1560	2860	N/A	N/A
315	12.00	STD/IN	779	335	1270	350	1284
315	12.00	STD/2MO	191.6	2498	4797	2534	4833
315	12.00	OT2/STD2	390.7	4743	9431	4817	9505
380	6.00	STD/OT	70	324	744	302	722
380	6.00	STD/2IO	171	791	1817	738	1764
380	6.00	Medium	600	1572	5172	1387	4987
380	6.00	E/HVY	1085	5018	11528	4679	11189

Note: **Suffix B** denotes baseplate actuators used to operate butterfly valves or similar.

**Table 4: P-Series Linear Spring Cylinder Actuator – Maximum available seating trust lbf**

Supply Pressure	Cylinder actuator size				Cylinder actuator size			
	Standard spring – Air fail close				Standard spring – Air fail open			
psig	25	50	100	200	25	50	100	200
40	1428	2780	5550	8320	663	1387	1987	6620
60	1985	3270	7780	12180	1220	2367	4205	10480
80	2540	4250	10000	16040	1776	3348	6432	14340
100	3098	5250	12230	19900	2333	4329	8659	18200
150	4490	7680	17800	29550	3724	6780	14226	27850

Note: The air pressure is applied above the piston in each case. Higher seating loads are available from using alternative springs.

# Air fail action

The standard range of springs shown in Table 3 (page 5) provide the main source available thrust for the P-Series actuators in the event of air failure.

However, some applications require even greater actuator air failure thrusts and this can be provided with the fitting of auxiliary equipment to utilise the supply air held within the cylinder volume in order to provide the additional thrust.

## Cylinder actuator with air spring

In this air fail safe system, the stored volume within the cylinder is used for failure protection and forms the air spring which is additional to any mechanical springs fitted internally in the cylinder. The normal double-acting positioner is operated as a three way unit to supply air to the underside of the cylinder piston. Should the valve drop below a predetermined level, air is locked onto the upper side of the cylinder piston in order to close the actuator. The control circuit includes a pressure regulator which is set to give the required level of pressure compatible with closing the actuator under failure conditions.

## Cylinder actuator with air spring and external volume tank

In some cases, the internal volume of the cylinder actuator is insufficient to cause the actuator/valve assembly to fully stroke upon air failure. To overcome this, an external volume tank is fitted to supply the additional air control circuit and the positioner now operates as a double-acting unit. Diagram 1 shows that additional lock-up valves have now been fitted to each side of the cylinder to both exhaust the underside of the piston and pressurise its topline in the event of air failure. The P-Series volume tank, along with the valve used for pressurising, is sized to ensure that the actuator will fully stroke.

## Fail fix in the event of air failure

Where applications require the system to hold the actuator in its last operating position in the event of air failure, a three way switching valve is used to sense the air supply (Diagram 2).

Failure of the air supply causes the valve to operate and initiate the signal connections. The two lock-up valves hold the existing pressure on both sides of the cylinder piston, thus locking it into place.

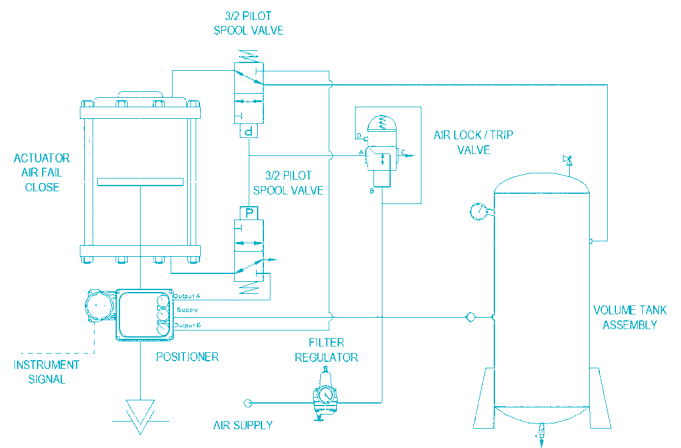

Diagram 1: Air spring using separate volume tank

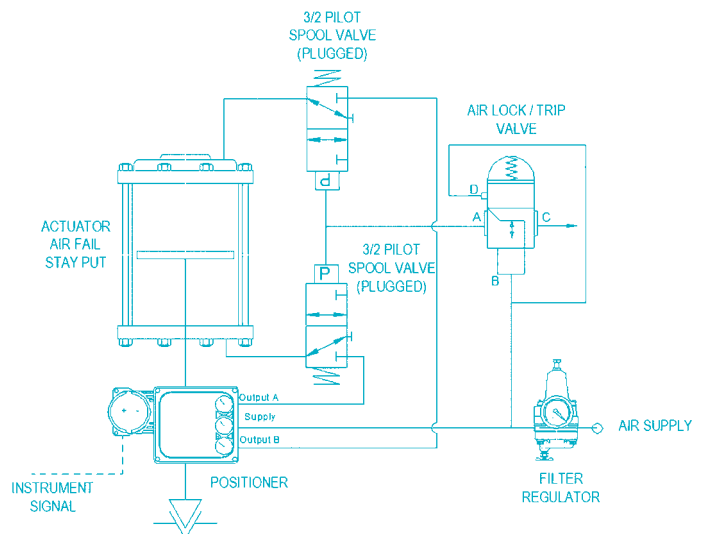

Diagram 2: Fail fix actuator lock-up configuration



# Improving actuator stroking speeds

P-Series Linear Spring Cylinder Actuators can be fitted with volume boosters in order to improve the response times and actuator stroking speeds (for more information please see specification bulletin number (SGI-B 10)).

**Table 5: P-Series Linear Spring Cylinder Actuator – Stroking speeds**

Actuator designation			With positioner *		With model IB10 booster	
Actuator	Stroke		Total time open	Total time close	Total time open	Total time close
Size	in	mm	sec	sec	sec	sec
25	0.75	20	<2	<2	1	1
25	4.00	100	<3	<3	<2	<2
50	1.50	40	<5	<5	<2	<2
50	4.00	100	<5	<4	3	<2
100	2.50	65	16	16	<4	<3.5
100	5.00	125	35	34	7	6.5
100	6.00	150	42	40	8	7.5
100	4.00	100	13.5	11	3	<2
200	5.00	125	65	62	15	14
200	6.00	150	75	73	15.5	14.5

\* Speed depends upon positioner selected and size fittings and of pipe work. The illustration data is based on a digital positioner calibrated at 4-20mA and 7bar air supply. Linear Spring Cylinder Actuator fitted with fail close standard spring.

Note:

- 1 Model 1000 Boosters fitted to top and bottom ports of Actuator, with 1/4in fittings between cylinder and boosters, and separate 12mm diameter feed for boosters. 7bar air supply used.
- 2 For sizes or strokes outside these listed or faster stroke speeds such as those used for anti surge applications please contact us.

## Hand wheel operators

Two types of geared hand wheel are available for fitting to the P-Series range of cylinder actuators, as follows:

- 1 Top mounted, continuously connected unit which is rated up to the full output thrust of the actuator.
- 2 Side mounted de-clutchable unit which is fitted below the actuator cylinder, leaving the top free for other accessories to be fitted. Table 6 shows the maximum output thrusts generated by these units.

### Continuously connected hand wheel

Designed by Severn, this hand wheel can be used to extend, or retract the stem as well as acting as either a high, or low limit stop. A neutral position is indicated on the mechanism when the actuator is in automatic operational mode. The geared unit is sealed within a weather resistant enclosure and the ratios selected ensure a low torque input for high output thrusts.

Turning the wheel moves the screw against the locknut in order to retract the stem. Moving the wheel in a counter clockwise direction brings the lower portion of the screw into contact with the shoulder on the stem, forcing the stem to extend.

A neutral position is obtained with the handwheel screw in any position other than the indicated central neutral, providing a stop to limit travel in either direction.

### De-clutchable hand wheel

Available throughout the range of actuator sizes up to 12in (300mm), the hand wheels are capable of providing forces in either direction. The gearing has been selected to ensure easy operation up to its maximum thrust capability (see Table 6 on page 8). The side mounted hand wheel unit may be fitted retrospectively if required. De-clutchable hand wheels provide the same positional accuracy as the positioning actuators. Fitted with a manual changeover valve the P-Series actuator is isolated during hand wheel operation.

### Positional accuracy

The de-clutchable hand wheels provide the same positional accuracy as the positioning actuators. Fitted with a manual changeover valve the P-Series Actuator is isolated during hand wheel operation.

# Hand wheel operators

**Table 6: De-clutchable side mounted hand wheel specification**

Actuator	Hand wheel diameter		Turns (in)	Turning force		Output thrust	
	in	mm	Travel	lbF	kgF	lbF	kgF
25	6	150	35	23	10	2000	910
50	8	203	45	45	20	3000	1360
100	10	254	45	46	21	5000	2270
200/5	12	305	60	50	23	7000	3180

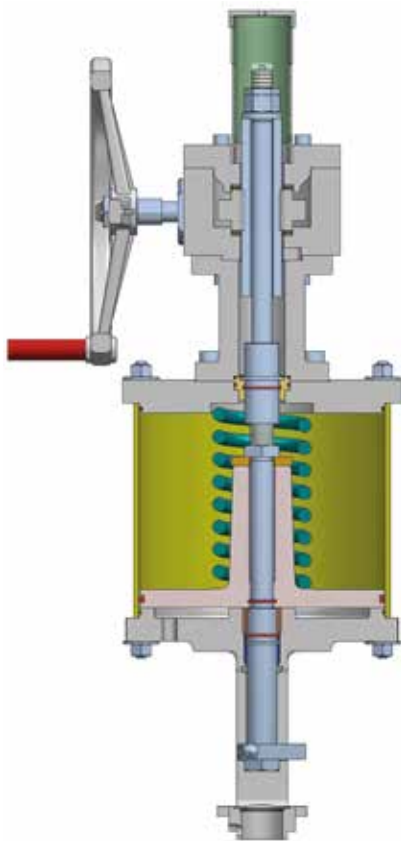

Top mounted continuously connected hand wheel and P-Series Actuator

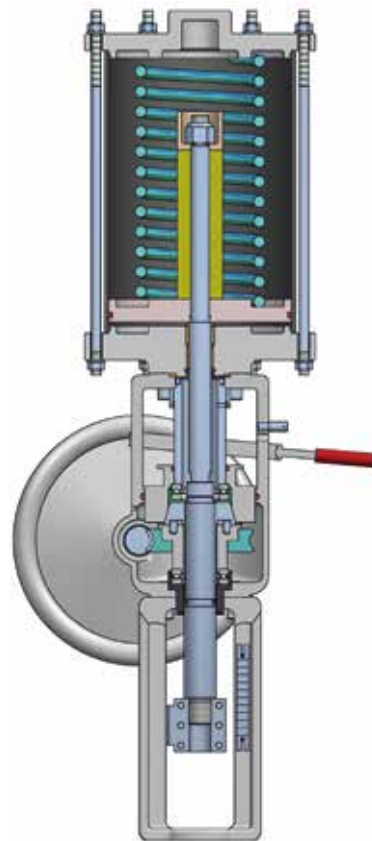

Side mounted de-clutchable hand wheel and P-Series Actuator

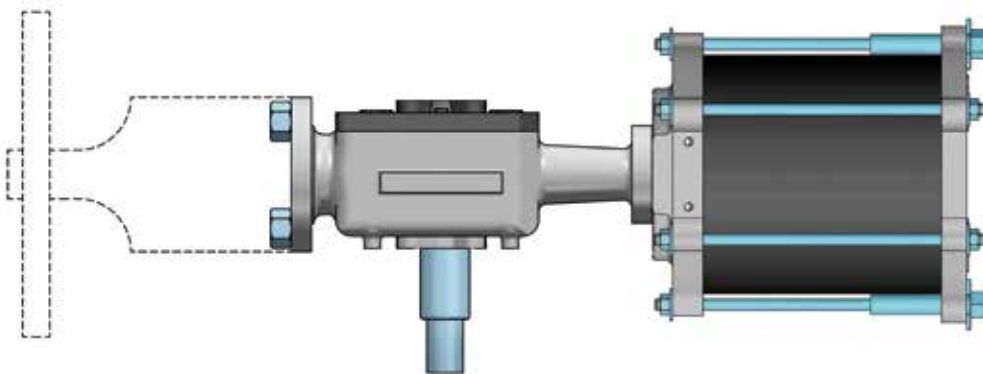

Side mounted de-clutchable hand wheel and P-Series Actuator

# Standard dimensions & weights

**Table 7: Dimensions**

Actuator	Diameter D		Length E		Length M1		Length E1		Length M2		Length E2	
	in	mm	in	mm	in	mm	in	mm	in	mm	in	mm
25	8.25	210	14.38	365	8.63	211	27.25	692	-	-	-	-
50	10.25	260	18.62	472	9	229	31.75	806	-	-	-	-
100-2.5	15.375	390	23.88	605	10.13	257	39.88	1013	-	-	-	-
100-6	15.375	390	40.9	1040	-	-	-	-	8.63	220	55.71	1415
100-12	15.375	390	53	1346	-	-	-	-	8.63	220	82	2085
200-6	20.75	527	44.30	1125	-	-	-	-	8.63	220	59.10	1500
200-12	20.75	527	56	1425	-	-	-	-	8.63	220	85	2160
315-12	24.8	630	59.84	1520	-	-	-	-	12.2	310	59.84	1520
380-6	26.77	680	45.67	1160	-	-	-	-	12.2	310	61.22	1555

**Table 8: Weights**

Actuator	Actuator only		With top mounted hand wheel		With side mounted hand wheel	
	lb	kg	lb	kg	lb	kg
25	21	9.5	49	22.2	-	-
50	36	16.3	72	32.7	-	-
100-2.5	85	38.6	145	65.8	-	-
200-6	340	155	-	-	510	232
315-12	1411	640	-	-	1609	730
380-6	1437	652	-	-	1642	745

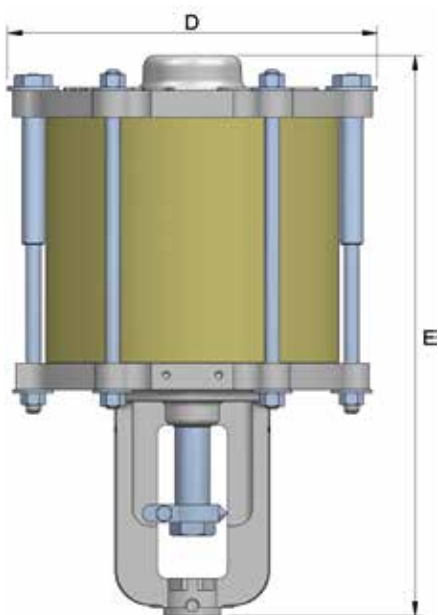

P Series dimensions

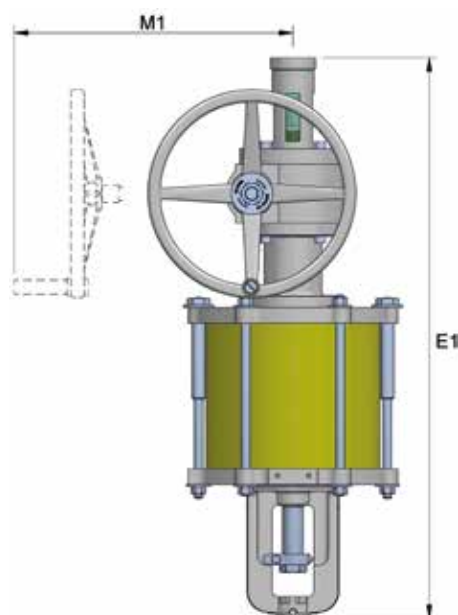

Top mounted hand wheel dimensions

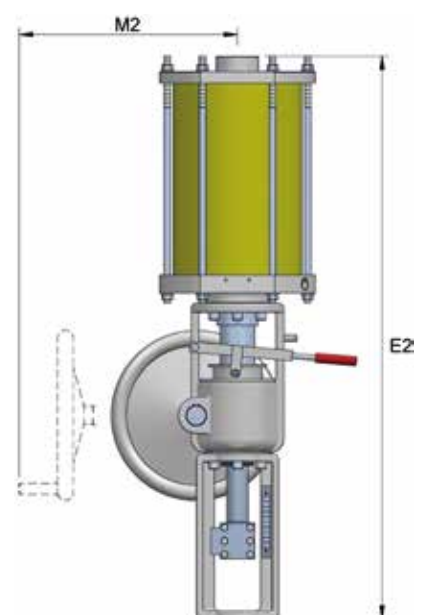

Side mounted hand wheel dimensions



**Vinnova Exploration**  
sales@vinnova.asia  
063-271-9119  
www.vinnova.asia



**Engineering  
Excellence**

**Head Office – Brighouse UK**  
Heywoods Industrial Park,  
Birds Royd Lane,  
Brighouse, HD6 1NA.

T: +44 (0)845 6070 710  
E: sales@severnvalve.com

**Gloucester UK**  
Olympus Park,  
Quedgeley,  
Gloucester, GL2 4NF.

T: +44 (0)845 223 2040  
E: sales@severnvalve.com

**Chennai India**  
F96 & F97, SIPCOT Industrial Park,  
Irrungattukottai, Chennai,  
Tamilnadu, India - 602 117.

T: +91 44 4710 4200  
E: sales@severnvalve.com

