

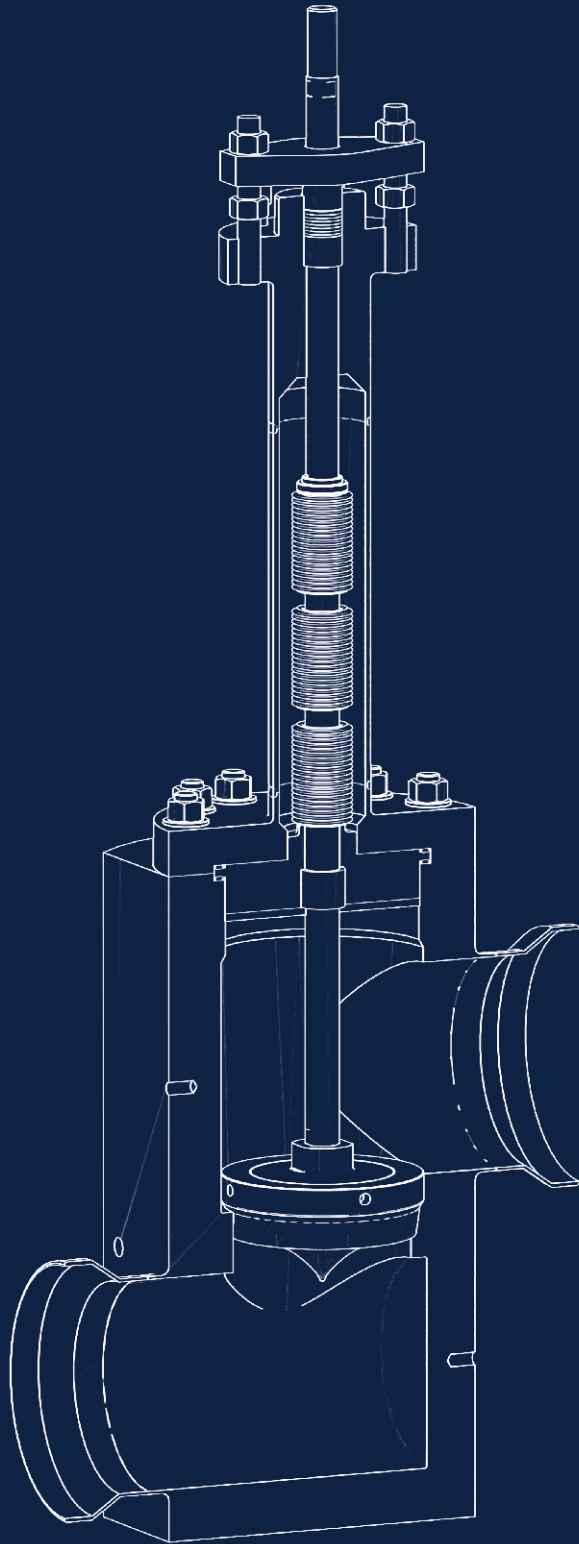

# 7000 Series UHP Control Valves

For ratings ANSI 150 – 300



It all flows from expertise.



# Contents

Introduction	01
Engineering data	02
Valve body style options	03
Design Cv Values	04
Dimensions	05

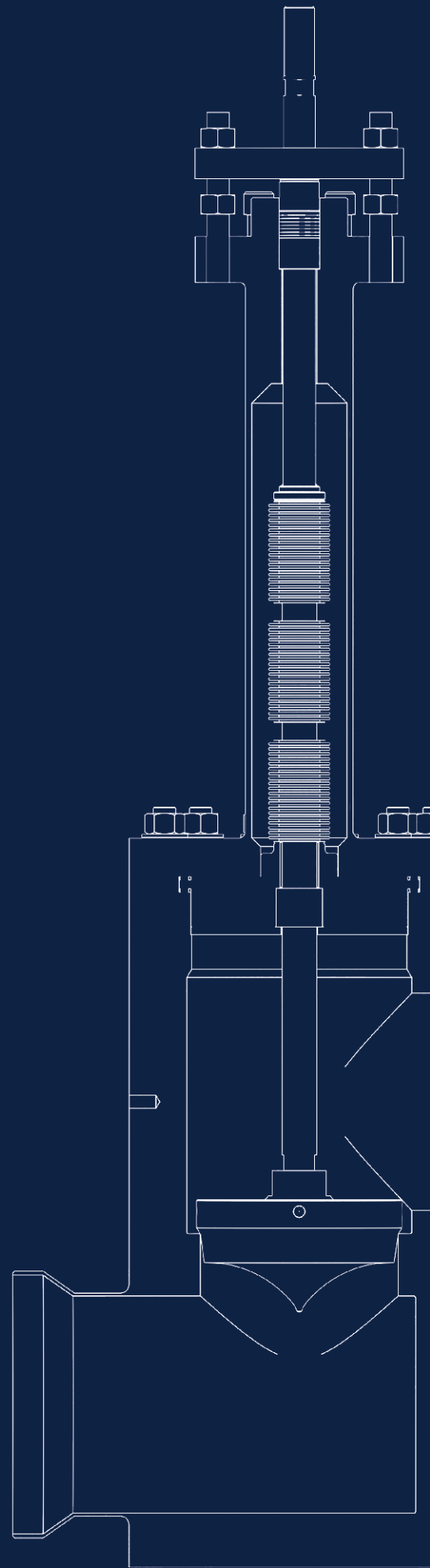

# 7000

## SERIES

The Severn 7000 Series was initially developed specifically for installations in cryogenic and warm service Ultra High Purity Systems for the semiconductor industry. As such the 7000 Series now benefits from extensive experience in providing cost effective and easily maintained valves in an industry that makes very stringent design demands upon its suppliers.

Compact installation has always been a major consideration in Severn designs and therefore Z or Angle styles are favoured over large Y pattern bodies. Construction materials of the body are generally forged 316L stainless steel to suit connecting pipework, while the fully machined crevice free flowpath minimises particle pick up and ensures the degree of cleanliness necessary for this sector of the Industrial gas market.

# Engineering Data

## Design features

- ✔ Smooth profile crevice free body construction
- ✔ High capacity body
- ✔ Electronic Grade surface finish options
- ✔ Large choice of trim sizes
- ✔ Robust parts for trouble free service and low cost of ownership
- ✔ Inherently characterised trims available in linear, equal percentage and semi throttle
- ✔ Bellows designed specifically for modulating service
- ✔ Soft seat insert option for ANSI Class VI
- ✔ Various options of weld end connections
- ✔ Perpendicular actuator orientation

## Quality engineered

- ✔ Extensive proven on-site performance
- ✔ BS EN ISO 9001 2015, Certificate No. FM525534

## General

The 7000 Series range of control valves were designed specifically for applications in the manufacture and distribution of Ultra High Purity gas/ liquid used primarily in the semi – conductor industry. As such they provide a cost effective, reliable and easily maintained control valve capable of being applied in a flexible manner to accommodate various approaches to UHP pipework installation. Reliability and ease of maintenance are essential features of any good control valve and the quick- change plug assembly provides for easy access to minimise any parts replacement times.

The specially designed forged bodies incorporate top guided contoured trim configuration which provides excellent rigidity and resistance to vibration and service wear. The valve is designed to accommodate other options within the Severn range e.g CC cages.

## Benefits

- ✔ Top entry servicing with direct access to plug assembly
- ✔ Reliable leakage performance, bubble Tight Shut Off available
- ✔ X – ray options on welds
- ✔ Interchangeability between other Severn products

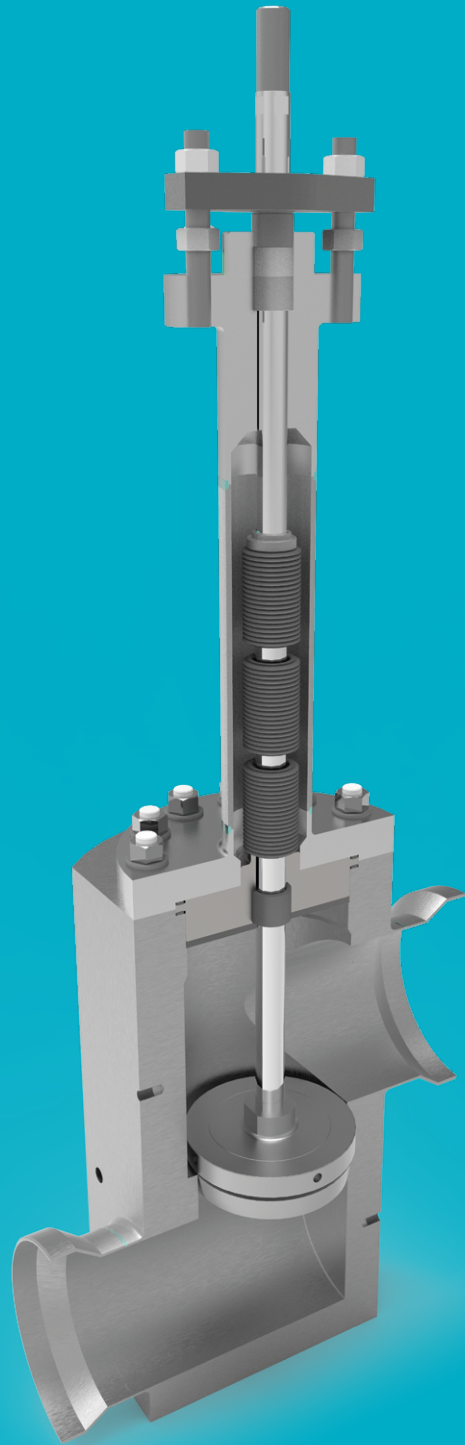

# Engineering Data

## End connection sizes/types

1/2in (12mm) – 8in (200mm)

## Design standards

ANSI B16-34 and design rated.

## Valve body ratings

ANSI 150 – ANSI 300.

## Body configurations

Globe, Angle and Z pattern.

## Body face to face dimensions

Severn Standard.

## Bonnet styles

Bellows (Primary Packing) and Cryogenic.

## Bellows

Designed to provide an infinite number of modulating cycles. Vacuum leak tested with helium to 10<sup>-8</sup> mbar x 1 x sec<sup>-1</sup>.

## Secondary packing

PTFE Chevrons.

## Trim options

Oversize, Full Size and Reduced Capacity, Unbalanced Contoured and Cage. See Table 1 for materials.

## Inherent trim characteristics

Equal %, Linear and Semi-throttle.

## Maximum plug / Seat leakage class

ANSI / FCI 70-2 Class IV as standard.

## Valve plug options

Unbalanced top guided. For port diameters see Table 5.

## Actuation

Various types of actuation are available including: Series P Linear spring pneumatic cylinder. Manually operated.

## Instruments

A wide range of control instruments are available from Severn including: Positioners, Volume Boosters, Solenoid Valves, Switches and Air-filter Regulators etc.

## Materials of construction

The standard body material is 316L Stainless Steel. For full listing see Table 1. All fabrication welds are full penetration type to eliminate the possibility of crevices with tube to body welds being made by orbital welding.

## Temperature range

-196°C to 220°C (-320°F to 428°F). For temperatures outside this range consult factory.

## Available connection styles

Tube ends – see Table 9. Options of pipe or ANSI.

## Assembly

All assembly takes place in a AFS 209E certified Clean Room using nitrogen / helium mix filtered to 0.2 microns for testing purposes.

## Packaging

Packing for equipment incorporates sealing in a clear plastic bag with a slight positive argon / nitrogen pressure and tagged "electronically clean."

## Valve body style options

The Severn 7000 Series UHP control valve is available in three body styles of Z pattern, angle or in line which utilise the same internal parts. In order to provide high integrity material formation demanded by the Semi Conductor industry.

The bodies are manufactured from forged 316L material thus eliminating imperfections and porosity. Compact installation has always been a major consideration in Severn designs and therefore both styles are favoured over large Y pattern bodies.

**Table 1. Materials of Construction**

Part	Materials
Body and Bonnet	Forged 316L Stainless Steel
Tube Ends	316L Stainless Steel
Optional Flanged or screwed Ends	316L Stainless Steel
Plug	316L Stainless Steel
Soft Seat	P.C.T.F.E. (KEL F)
Guide (bottom)	Reinforced P.T.F.E.
Guide (top)	Reinforced P.T.F.E.
Bellows	316L Stainless Steel
Gland Packing	PTFE Chevrons
Gland Packing Follower	321 Stainless Steel
Gland Flange and Bolting	Stainless Steel
Actuator Yoke Retaining Rings	Stainless Steel
Bonnet Studs and Nuts	B 8TX / 8MX
Body Gaskets	Spiral Wound St St/ P.T.F.E filled

**Table 2. Surface Finish Options**

Options	Surface Finish
Standard	<63 Ra – 1.6 micron (63 microinch) all wetted parts
High Purity	<20 Ra – 0.5 micron (20 microinch) all wetted parts – no Electro Polish
Ultra High Purity	<8 Ra – 0.2 micron (8 microinch) all wetted parts – full Electro Polish

**Standard bonnet**

This bonnet arrangement provides for a positive metallic gland seal, within the rated pressure and temperature of the bellows material selected. Generally used in UHP service to ensure non ingress of impurities into the process. An auxiliary packing box serving as a back-up seal in the unlikely event of a bellows failure is provided together with a tapped sensing port. The application temperature for this design is -196°C to 220°C.

**Extended bonnet**

The extended bonnet is available in a selection of lengths to enable the valve to be installed in insulating pipework and a cold box. The bellows retains any cryogenic liquid in the body of the valve which protects the auxiliary packing from coming into contact with it.

**Trim Options Available**

**Standard**

Standard Severn UHP trim consists of a top guided plug and integral seat machined in the body thus avoiding unnecessary crevices. The guiding area of the plug stem is highly polished and runs in a Kel F guide that is located close to the plug head in order to provide the high degree of stability necessary for good control. A wide variety of reduced capacity plugs are also available.

**Soft seated**

When leakage across the seat needs to be reduced to a minimum or be "bubble tight" then a soft seat insert is incorporated in the plug. The material used for the seal is Kel F due to its low shedding characteristics whilst all the other components remain in 316L stainless steel.

**Low noise**

The applications involving venting/depressurising etc a multi-hole low noise cage can be fitted in order to reduce valve emitted noise by as much as 15 dbA.

**Severn 7000 Series – Design Cv Values**

**Table 3. Flow Coefficient Cv**

The values detailed in the tables are stated in US units. The figures by definition are related to the flow of water (SG=1) through the valve at full lift in US Gallons per minute with a pressure drop of 1lb/in2.

Valve Size		Available Trim Cv's						
in	mm	Full and Reduced **						Override*
1/2	12		0.5	2.5	4			
3/4	20			2.5	4	9		
1	25				6	9	12	25
1.5	40				9	12	25	46
2	50				12	25	46	110
3	80				25	46	110	200
4	100				75	135	200	400
6	150				200	275	440	650
8	200				275	440	650	N/A

All Cv's are available either as contoured or ICC.

**Table 4. Weight lbs in (brackets)**

Size	1/2 – 1	1.5	2	3	4	6	8
Weight (Std)	45kg (100)	48kg (106)	52kg (114)	90kg (200)	120kg (266)	184kg (408)	343kg (754)
Weight (O/S)	50kg (110)	53kg (117)	57kg (125)	100kg (220)	133kg (293)	201kg (443)	337kg (829)

Note: Weights apply to valve, actuator, positioner and airset

**Table 5. Tube End Dimensions**

Nominal Size in	Imperial, OD x thickness in	Equivalent Metric
1/2	0.0250 x 0.035	6.35 x 0.91mm
3/8	0.0375 x 0.035	9/53 x 0.91mm
1/2	0.500 x 0.049	12.7 x 1.24mm
3/4	0.75 x 0.049	19.05 x 1.24mm
1	1 x 0.065	25.40 x 1.65mm
1 1/2	1.50 x 0.065	38.10 x 1.65mm
2	2 x 0.065	50.80 x 1.65mm
3	3 x 0.065	76.10 x 1.65mm
4	4 x 0.080	101.60 x 2.03mm
6	6 x 0.080	152.40 x 2.03mm
8	Check with factory	

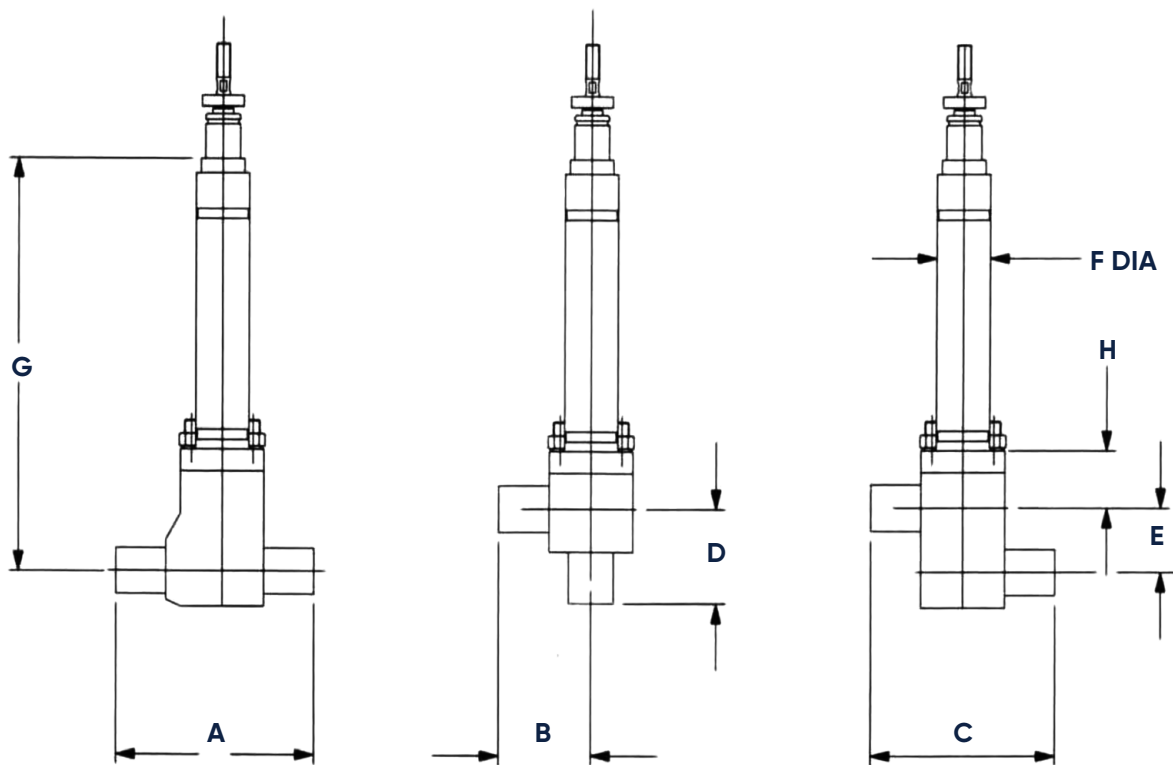

**Table 6**

Valve Size	A		B		C		D		E		F		G		H				
	in	mm	in	mm	in	mm	in	mm	in	mm	in	mm	COLD	WARM					
0.50	12.5	14.25	362	4.94	125	9.88	251	5.50	140	2.25	57	1.90	48	13.69	348	10.69	272	150	40
0.75	20	14.25	362	4.94	125	9.88	251	5.50	140	2.25	57	1.90	48	13.69	348	10.69	272	2.0	50
1.00	25	14.25	362	4.94	125	9.88	251	5.50	140	2.25	57	1.90	48	13.69	348	10.69	272	2.0	50
1.50	40	15.88	403	5.88	150	11.75	298	6.88	175	2.75	70	1.90	48		16.31	414		2.62	67
2.00	50	17.25	438	5.81	148	11.62	295	7.88	200	3.50	89	1.90	48		17.88	454		3.0	40
3.00	80			8.19	208	16.38	416	9.50	241	4.25	108	3.50	89		24.00	610		4.0	100
4.00	100			10.75	273	21.50	546	12.12	308	5.25	133	3.50	89		24.75	629		5.0	127
6.00	150			12.25	311	24.50	622	14.25	362	7.75	197	3.50	89		27.12	689			



**Vinnova Exploration**

sales@vinnova.asia  
063-271-9119  
www.vinnova.asia



Engineering  
Excellence

**Head Office – Brighouse UK**

Heywoods Industrial Park,  
Birds Royd Lane,  
Brighouse, HD6 1NA.

T: +44 (0)845 6070 710  
E: sales@severnvalve.com

**Gloucester UK**

Olympus Park,  
Quedgeley,  
Gloucester, GL2 4NF.

T: +44 (0)845 223 2040  
E: sales@severnvalve.com

**Chennai India**

F96 & F97, SIPCOT Industrial Park,  
Irrungattukottai, Chennai,  
Tamilnadu, India – 602 117.

T: +91 44 4710 4200  
E: sales@severnvalve.com

[www.severnvalve.com](http://www.severnvalve.com)

Our policy is one of continuous improvement and we reserve the right to modify these specification details without notice.

V1.1