

# Mark EZ Series

## Globe Style Control Valve

### Excellent Pressure and Flow Control:

Mark EZ valves are globe-style with integral end connections, post guiding, and quick-change trim. Typical applications include chemical or hydrocarbon processing, as well as applications that require control of viscous, non-lubricating or other hard-to-handle fluids. End Connection Styles are flanged Class 150, 300, and 600 raised face, ring type joint or flat face as per ASME B16.5 or screwed/socket welding consistent with ASME B16.1.

Maximum Inlet Pressures<sup>1</sup> for flanged connections are consistent with Class 150, 300, or 600 as per ASME B16.34. Screwed connections are consistent with Class 600 as per ASME B16.34-latest edition.

<sup>1</sup> The pressure/temperature limits in this manual and any applicable standard or code limitation for valve should not be exceeded.



Mark EZ Valve

### FEATURES

- Characterized flow options including equal percentage, linear, and quick opening
- Available in variety of body and trim materials, the Mark EZ Series suitable for a variety of applications
- Quick change trim for easy maintenance
- Sour service capability: Optional NACE MRO175/ISO 15156-2009
- Tight shutoff



Jordan Valve, a division of Richards Industries  
3170 Wasson Road • Cincinnati, OH 45209  
513.533.5600 • 800.543.7311 • 513.871.0105 (f)  
info@richardsind.com • www.jordanvalve.com



Vinnova Exploration  
sales@vinnova.asia  
063-271-9119  
www.vinnova.asia

**SPECIFICATIONS**

**Sizes:** 1-4"

**End Connections:**

- ANSI Flanges- Class 150, 300 and 600
- Raised Face, or Ring Type Joint flanges as per ASME B16.34-latest edition.

**Body Materials:**

- LCC
- WCB
- WCC
- WC9
- C5
- Monel
- CF8M SST
- Additional materials may be available upon request

**Trim Materials:**

- 316SST
- 416SST
- 17-4PH
- Alloy6-Co.Cr-A
- Cobalt
- 316SST/Tungsten Carbide

**Seats:**

- Metal
- PTFE

**Shutoff:** ANSI Class IV & V

**Maximum Inlet Pressures and Temperatures:** The Maximum Inlet Pressure and Temperature is consistent with ASME Class per ASME 16.34.

**Maximum Pressure Drops:** All valves are capable of Full Rated Pressure Drops

**Flow Characteristics:**

- Quick opening
- Linear
- Equal percentage

**Trim Options:**

- Noise abatement
- Anti-cavitation

**Flow Direction:** Flow up through the seat ring

**Valve Travel Indication:** Valves are supplied with Visual Travel Indicator

**DIMENSIONS**

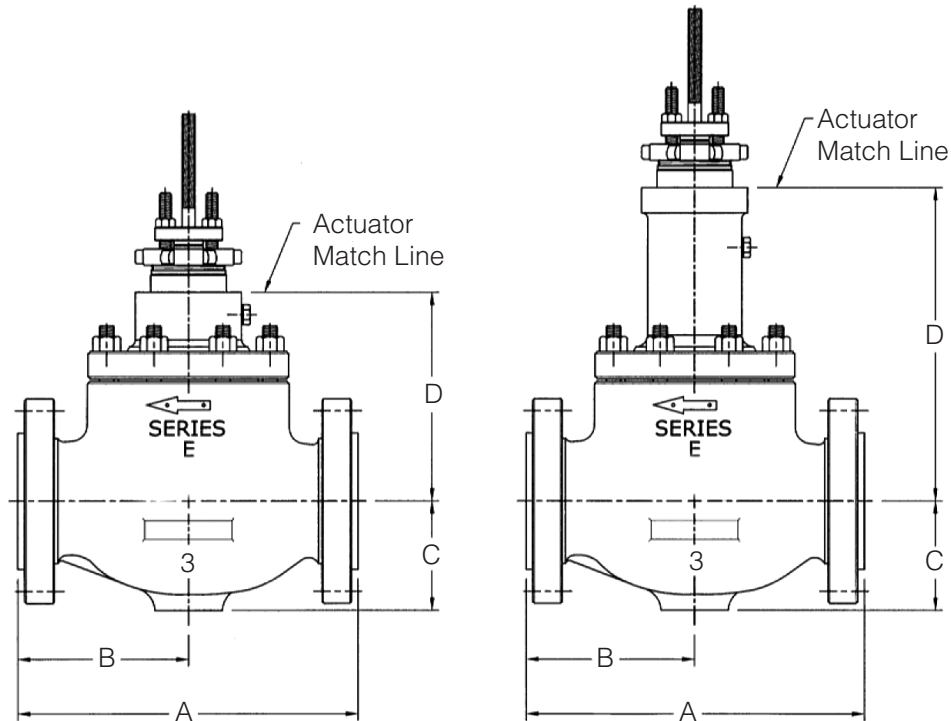

MARK EZ SERIES GLOBE STYLE CONTROL VALVE

Steel Bodies through 600lb Rating

Valve Size		Dimension A <sup>1</sup>											
		150 RF		150 RTJ		300 RF		300 RTJ		600 RF		600 RTJ	
in	mm	in	mm	in	mm	in	mm	in	mm	in	mm	in	mm
1	25,4	7.25	184,2	7.75	169,9	7.75	169,9	8.25	209,6	8.25	209,6	8.25	209,6
1-1/2	38,1	8.75	222,3	9.25	235,0	9.25	235,0	9.75	247,7	9.88	251,0	9.88	251,0
2	50,8	10.00	254,0	10.50	266,7	10.50	266,7	11.13	282,7	11.25	285,8	11.38	289,1
2-1/2	63,5	10.88	276,4	11.38	289,1	11.50	292,1	12.13	308,1	12.25	311,2	12.38	314,5
3	76,2	11.75	298,5	12.25	311,2	12.5	317,5	13.13	333,5	13.25	333,6	13.38	339,9
4	101,6	13.88	352,6	14.38	365,3	14.51	368,3	15.13	384,3	15.50	393,7	15.63	397,0

<sup>1</sup> Dimension B = Dim. A divided by 2; RF=Raised Face; RTJ=Ring Type Joint; Flange Spec. ASME/ANSIB16.5 - 1996

Valve Size		Dimension C											
		150 RF		150 RTJ		300 RF		300 RTJ		600 RF		600 RTJ	
in	mm	in	mm	in	mm	in	mm	in	mm	in	mm	in	mm
1	25,4	2.13	54,1	2.13	54,1	2.13	54,1	2.13	54,1	2.13	54,1	2.13	54,1
1-1/2	38,1	2.44	61,9	2.44	61,9	2.44	61,9	2.44	61,9	2.44	61,9	2.44	61,9
2	50,8	2.88	73,2	2.88	73,2	2.88	73,2	2.88	73,2	2.88	73,2	2.88	73,2
2-1/2	63,5	3.44	87,4	3.44	87,4	3.44	87,4	3.44	87,4	3.44	87,4	3.44	87,4
3	76,2	3.56	90,4	3.56	90,4	3.56	90,4	3.56	90,4	3.56	90,4	3.56	90,4
4	101,6	4.69	119,1	4.69	119,1	4.81	119,1	4.81	119,1	4.94	125,5	4.94	125,5

Valve Size		Dimension D											
		Standard Bonnet						Extension Bonnet					
		Stem Size						Stem Size					
in	mm	3/8	9,5	1/2	12,7	3.4	19,1	3/8	9,5	1/2	12,7	3.4	19,1
		in	mm	in	mm	in	mm	in	mm	in	mm	in	mm
1	25,4	5	127,0	5.88	150	---	---	8.38	212,8	9.88	251,0	---	---
1-1/2	38,1	4.88	123,8	5.75	146,1	---	---	8.25	209,6	9.75	247,7	---	---
2	50,8	---	---	6.50	165,1	6.38	162,1	---	---	10.50	266,7	10.50	266,7
2-1/2	63,5	---	---	7.38	187,5	7.25	184,2	---	---	10.50	266,7	10.50	266,7
3	76,2	---	---	7.50	190,5	7.38	187,5	---	---	11.50	292,1	11.69	296,9
4	101,6	---	---	8.69	221,0	8.56	217,4	---	---	12.69	322,3	12.88	327,2

RF=Raised Face; RTJ=Ring Type Joint; Flange Specification ASME/ANSIB16.5 - 1996

Valve Size, Inches	Weight	
	Lbs	Kg
1, 1-1/4	30	14
1-1/2	45	20
2	68	31
2-1/2	100	45
3	125	57
4	170	78

Approximate Weights- Without Actuator

## MARK EZ SERIES GLOBE STYLE CONTROL VALVE

Quick Open - Flow Up - Mark EZ, Quick Opening Valve Plug																	
Valve Size, NPS	Port Diameter		Maximum Travel		Flow Coefficient	Cv for 0.25" (6mm) Travel (1)	Valve Opening- Percent of Total Travel										FL (2)
	in.	mm	in.	mm			10	20	30	40	50	60	70	80	90	100	
1	1	25,4	0.75	19	Cv	14.7	4.39	10.3	14.0	15.5	16.2	16.6	16.8	16.8	16.9	16.9	0.94
					Kv	12.7	3.80	8.91	12.1	13.4	14.0	14.4	14.5	14.5	14.6	14.6	---
					XT	14.7	0.400	0.449	0.523	0.539	0.535	0.512	0.500	0.500	0.494	0.494	---
					Fd	---	0.20	0.29	0.39	0.48	0.50	0.50	0.50	0.50	0.50	0.50	---
1- 1/2	1.5	38,1	0.75	19	Cv	22.6	5.64	11.9	20.6	27.4	30.5	32.4	33.4	33.7	34.1	34.2	0.96
					Kv	19.5	4.88	10.3	17.8	23.7	26.4	28.0	28.9	29.2	29.5	29.6	---
					XT	22.6	0.623	0.734	0.726	0.814	0.843	0.857	0.861	0.860	0.853	0.848	---
					Fd	---	0.16	0.24	0.32	0.39	0.45	0.50	0.50	0.50	0.50	0.50	---
	1(4)	25,4 (4)	0.75	19	Cv	15.7	4.17	8.94	14.6	17.4	18.3	18.8	18.9	19.0	19.1	19.4	0.90
					Kv	13.6	3.61	7.73	12.6	15.1	15.8	16.3	16.3	16.4	16.5	16.8	---
					XT	15.7	0.617	0.791	0.793	0.904	0.925	0.924	0.922	0.915	0.905	0.878	---
2	2	50,8	1.125	29	Cv	34.0	13.0	30.1	44.3	52.4	56.4	57.8	58.4	58.5	58.6	58.6	0.94
					Kv	29.4	11.2	26.0	38.3	45.3	48.8	50.0	50.5	50.6	50.7	50.7	---
					XT	34.0	0.548	0.663	0.765	0.813	0.818	0.833	0.831	0.836	0.834	0.834	---
					Fd	---	0.17	0.28	0.36	0.43	0.49	0.50	0.50	0.50	0.50	0.50	---
	1(4)	24,4 (4)	0.75	19	Cv	15.8	4.35	9.79	14.9	16.6	17.3	17.5	17.5	17.6	17.7	17.9	0.86
					Kv	13.7	3.76	8.47	12.9	14.4	15.0	15.1	15.1	15.2	15.3	15.5	---
					XT	15.8	0.524	0.594	0.695	0.877	0.937	0.944	0.958	0.952	0.942	0.921	---
3	3	76,2	1.5	38	Cv	53.8	30.8	65.1	92.4	110	118	123	126	128	129	129	0.91
					Kv	46.5	26.6	56.3	79.9	95.2	102	106	109	111	112	112	---
					XT	53.8	0.672	0.714	0.713	0.742	0.784	0.785	0.783	0.766	0.774	0.774	---
					Fd	---	0.17	0.27	0.35	0.42	0.47	0.50	0.50	0.50	0.50	0.50	---
	2(4)	50,8 (4)	1.125	29	Cv	32.2	9.99	27.6	44.9	61.0	71.9	78.4	83.1	86.2	87.5	88.4	0.95
					Kv	27.9	8.64	23.9	38.8	52.8	62.2	67.8	71.9	74.6	75.7	76.5	---
					XT	32.2	0.527	0.511	0.652	0.720	0.780	0.820	0.814	0.798	0.790	0.779	---
4	4	101,6	2	51	Cv	68.2	50.8	116	159	185	201	212	219	222	223	223	0.88
					Kv	59.0	43.9	100	138	160	174	183	189	192	193	193	---
					XT	68.2	0.733	0.653	0.724	0.805	0.809	0.816	0.809	0.812	0.831	0.835	---
					Fd	---	0.18	0.28	0.36	0.42	0.48	0.50	0.50	0.50	0.50	0.50	---
	2(4)	50,8 (4)	1.125	29	Cv	37.4	13.5	32.3	52.2	66.2	74.4	81.1	85.0	85.8	86.3	86.7	0.85
					Kv	32.4	11.7	27.9	45.2	57.3	64.4	70.2	73.5	74.2	74.6	75.0	---
					Xt	37.4	0.490	0.556	0.609	0.672	0.793	0.772	0.728	0.714	0.711	0.704	---

1. Self operated regulators
2. At 100% travel
3. Restricted Trim

MARK EZ SERIES GLOBE STYLE CONTROL VALVE

Linear - Flow Up – Mark EZ, Linear Valve Plug

Valve Size, NPS	Port Diameter		Maximum Travel		Flow Coefficient	Valve Opening- Percent of Total Travel										FL (1)
	in.	mm	in.	mm		10	20	30	40	50	60	70	80	90	100	
1	1	25,4	0.75	19	Cv	2.21	3.87	5.29	6.56	8.2	9.82	11.1	12.1	13.6	13.6	0.96
					Kv	1.91	3.35	4.58	5.67	7.09	8.49	9.60	10.5	11.2	11.8	---
					XT	0.638	0.601	0.638	0.634	0.638	0.624	0.636	0.680	0.769	0.834	---
1- 1/2	1.5	38,1	0.75	19	Cv	3.99	7.53	11.1	14.8	18.7	22.5	25.8	29.2	31.2	31.9	0.96
					Kv	3.45	6.51	9.6	12.8	16.2	19.5	22.3	25.3	27.0	27.6	---
					XT	0.633	0.651	0.657	0.691	0.674	0.674	0.696	0.704	0.757	0.818	---
	1(2)	25,4 (2)	0.75	19	Cv	1.96	3.42	4.94	6.11	7.8	9.3	10.9	13	15.1	16.7	0.96
					Kv	1.70	2.96	4.27	5.29	6.75	8.04	9.43	11.2	13.1	14.4	---
					XT	0.469	0.578	0.600	0.690	0.652	0.655	0.637	0.625	0.719	0.796	---
2	2	50,8	1.125	29	Cv	6.08	11.9	18.0	24.1	30.1	36.4	42.8	49.9	52.0	52.4	0.95
					Kv	5.26	10.3	15.6	20.8	26.0	31.5	37.0	43.2	45.0	45.3	---
					XT	0.560	0.644	0.655	0.675	0.701	0.724	0.779	0.773	0.862	0.924	---
	1(2)	24,4 (2)	0.75	19	Cv	1.88	3.41	4.95	6.49	8.06	9.67	11.23	12.79	14.35	15.7	0.94
					Kv	1.63	2.95	4.28	5.61	6.97	8.36	9.71	11.1	12.4	13.6	---
					XT	0.609	0.593	0.597	0.624	0.621	0.626	0.642	0.633	0.750	0.910	---
3	3	76,2	1.5	38	Cv	15.4	29.6	43.4	58.3	71.8	83.9	93.8	103	108	110.4	0.92
					Kv	13.3	25.6	37.5	50.4	62.1	72.6	81.1	89.1	93.4	95.5	---
					XT	0.622	0.642	0.692	0.691	0.690	0.721	0.759	0.788	0.839	0.888	---
	2(2)	50,8 (2)	1.125	29	Cv	6.59	13.1	20.7	28.1	36.0	44.0	55.6	67.5	76.2	80.4	0.94
					Kv	5.70	11.5	17.9	24.3	31.1	38.1	48.1	58.4	65.9	69.5	---
					XT	0.564	0.500	0.522	0.609	0.577	0.594	0.563	0.582	0.677	0.749	---
4	4	101,6	2	51	Cv	21.3	39.7	57.5	75.8	100	129	157	180	199	209	0.89
					Kv	18.4	34.3	49.7	65.6	86.5	112	136	156	172	181	---
					XT	0.554	0.628	0.684	0.723	0.665	0.608	0.677	0.826	0.862	0.866	---
	2(2)	50,8 (2)	1.125	29	Cv	6.16	12.8	20.0	27.8	36.1	45.1	58.8	67.5	78.8	86.8	0.90
					Kv	5.33	11.1	17.3	24.0	31.2	39.0	50.9	58.4	68.2	75.1	---
					Xt	0.740	0.644	0.642	0.619	0.602	0.605	0.552	0.614	0.644	0.736	---

1. At 100% travel
2. Restricted Trim

MARK EZ SERIES GLOBE STYLE CONTROL VALVE

Equal Percentage - Flow Up – Mark EZ, Equal Percent Valve Plug

Valve Size, NPS	Port Diameter		Maximum Travel		Flow Coefficient	Valve Opening- Percent of Total Travel										FL (1)
	in.	mm	in.	mm		10	20	30	40	50	60	70	80	90	100	
1	1	25.4	0.75	19	Cv	0.79	1.25	1.80	2.53	3.63	5.28	7.59	10.7	12.7	13.2	0.96
					Kv	0.683	1.08	1.56	2.19	3.14	4.57	6.57	9.26	11.0	11.4	---
					XT	0.641	0.634	0.598	0.586	0.584	0.596	0.646	0.680	0.757	0.886	---
					Fd	0.091	0.11	0.13	0.16	0.19	0.24	0.30	0.37	0.43	0.50	---
1- 1/2	1.5	38.1	0.75	19	Cv	0.795	1.23	1.91	2.95	4.30	6.46	9.84	16.4	22.2	28.1	0.97
					Kv	0.688	1.06	1.65	2.55	3.72	5.59	8.51	14.2	19.2	24.3	---
					XT	0.726	0.676	0.733	0.645	0.589	0.558	0.597	0.653	0.777	0.840	---
					Fd	0.077	0.086	0.10	0.12	0.15	0.17	0.22	0.27	0.34	0.40	---
	1(2)	25.4 (2)	0.75	19	Cv	0.770	1.23	1.78	2.58	3.67	5.54	8.30	12.0	15.1	17.3	0.98
					Kv	0.666	1.06	1.54	2.23	3.17	4.79	7.18	10.4	13.1	15.0	---
					XT	0.654	0.619	0.601	0.605	0.561	0.534	0.518	0.575	0.704	0.861	---
2	2	50.8	1.125	29	Cv	1.65	2.61	4.30	6.62	11.1	20.7	32.8	44.7	50.0	53.8	0.95
					Kv	1.43	2.26	3.72	5.73	9.60	17.9	28.4	38.7	43.3	46.5	---
					XT	0.655	0.581	0.520	0.559	0.552	0.529	0.653	0.801	0.903	0.899	---
					Fd	0.069	0.085	0.11	0.13	0.18	0.23	0.30	0.37	0.44	0.50	---
	1(2)	24.4 (2)	0.75	19	Cv	1.02	1.50	2.05	2.78	3.90	5.57	8.16	11.8	14.5	15.9	0.92
					Kv	0.882	1.30	1.77	2.40	3.37	4.82	7.06	10.2	12.5	13.8	---
					XT	0.596	0.616	0.600	0.580	0.572	0.555	0.523	0.547	0.671	0.905	---
3	3	76.2	1.5	38	Cv	3.11	5.77	9.12	13.7	21.7	36.0	60.4	86.4	104	114	0.92
					Kv	2.69	4.99	7.89	11.9	18.8	31.1	52.2	74.7	90.0	98.6	---
					XT	0.619	0.595	0.598	0.619	0.594	0.563	0.586	0.729	0.788	0.781	---
					Fd	0.062	0.081	0.10	0.12	0.16	0.20	0.26	0.33	0.40	0.46	---
	2(2)	50.8 (2)	1.125	29	Cv	2.11	3.11	4.58	6.76	10.7	20.7	34.3	48.3	61.5	71.6	0.92
					Kv	1.83	2.69	3.96	5.85	9.26	17.9	29.7	41.8	53.2	61.9	---
					XT	0.874	0.699	0.643	0.626	0.587	0.451	0.493	0.587	0.648	0.734	---
4	4	101.6	2	51	Cv	4.90	8.19	13.5	20.1	31.2	52.6	96.7	140	170	190	0.90
					Kv	4.24	7.08	11.7	17.4	27.0	45.5	83.6	121	147	164	---
					XT	0.594	0.573	0.560	0.568	0.572	0.564	0.532	0.707	0.807	0.834	---
					Fd	0.052	0.065	0.080	0.10	0.13	0.17	0.23	0.31	0.38	0.44	---
	2(2)	50.8 (2)	1.125	29	Cv	1.96	3.05	4.43	6.98	11.9	22.3	36.7	50.9	61.8	72.7	0.92
					Kv	1.70	2.64	3.83	6.04	10.3	19.3	31.7	44.0	53.5	62.9	---
					Xt	0.619	0.575	0.624	0.610	0.678	0.639	0.646	0.673	0.778	0.781	---

- 1. At 100% travel
- 2. Restricted Trim

## MARK EZ SERIES GLOBE STYLE CONTROL VALVE

### M-Form - Flow Up – Mark EZ, Equal Percentage Characteristic

Valve Size, NPS	Port Diameter		Maximum Travel		Flow Coefficient	Valve Opening- Percent of Total Travel											FL (1)
	in.	mm	in.	mm		5	10	20	30	40	50	60	70	80	90	100	
All Sizes 1 1-1/2 2	0.25	6.4	0.75	19	Cv	0.075	0.088	0.124	0.175	0.236	0.327	0.464	0.641	0.881	1.22	1.52	0.88
					Kv	0.065	0.076	0.107	0.151	0.204	0.283	0.401	0.554	0.762	1.06	1.31	---
					XT	0.804	0.771	0.717	0.658	0.645	0.620	0.585	0.596	0.596	0.603	0.647	---
1	0.375	9.5	0.75	19	Cv	0.099	0.129	0.199	0.308	0.448	0.620	0.882	1.29	1.80	2.43	3.07	0.89
					Kv	0.086	0.112	0.172	0.266	0.388	0.536	0.763	1.12	1.56	2.10	2.66	---
					XT	0.795	0.747	0.663	0.641	0.593	0.569	0.568	0.560	0.571	0.624	0.662	---
	0.5	12.7	0.75	19	Cv	0.133	0.189	0.319	0.492	0.735	1.08	1.53	2.12	2.99	4.17	4.91	0.93
					Kv	0.115	0.163	0.276	0.426	0.636	0.934	1.32	1.83	2.59	3.61	4.25	---
					XT	0.787	0.728	0.639	0.628	0.591	0.573	0.585	0.600	0.618	0.645	0.803	---
	0.75	19.1	0.75	19	Cv	0.276	0.374	0.622	0.965	1.47	2.17	3.15	4.57	6.52	8.17	8.84	0.97
					Kv	0.239	0.324	0.538	0.835	1.27	1.88	2.72	3.95	5.64	7.07	7.65	---
					XT	0.723	0.687	0.614	0.588	0.560	0.571	0.596	0.603	0.624	0.750	0.919	---
1-1/2 & 2	0.375	9.5	0.75	19	Cv	0.096	0.121	0.190	0.302	0.435	0.600	0.864	1.26	1.80	2.56	3.20	0.84
					Kv	0.083	0.105	0.164	0.261	0.376	0.519	0.747	1.09	1.56	2.21	2.77	---
					XT	0.923	0.915	0.763	0.699	0.657	0.640	0.624	0.608	0.596	0.594	0.648	---
	0.5	12.7	0.75	19	Cv	0.145	0.199	0.323	0.503	0.735	1.07	1.54	2.14	3.08	4.36	5.18	0.91
					Kv	0.125	0.172	0.279	0.435	0.636	0.926	1.33	1.85	2.66	3.77	4.48	---
					XT	0.851	0.748	0.686	0.640	0.617	0.627	0.602	0.607	0.607	0.573	0.705	---
	0.75	19.1	0.75	19	Cv	0.336	0.434	0.683	1.00	1.49	2.21	3.18	4.61	6.73	8.88	10.2	0.92
					Kv	0.291	0.375	0.591	0.865	1.29	1.91	2.75	3.99	5.82	7.68	8.82	---
					XT	0.784	0.747	0.625	0.636	0.596	0.578	0.603	0.593	0.591	0.680	0.796	---

1. At 100% travel

## MARK EZ SERIES GLOBE STYLE CONTROL VALVE

## M-Flute - Flow Up – Mark EZ, Equal Percentage Characteristic

Valve Size, NPS	Port Diameter		Maximum Travel		Flow Coefficient	Valve Opening- Percent of Total Travel										FL (1)
	mm	in.	mm	in.		10	20	30	40	50	60	70	80	90	100	
All Sizes 1 1-1/2 2	6,4 1 Flute	0,25 1 Flute	19	0,75	Cv	0.0385	0.0455	0.0560	0.0719	0.0942	0.124	0.162	0.212	0.278	0.354	0.87
					Kv	0.033	0.039	0.048	0.062	0.081	0.107	0.140	0.183	0.240	0.306	---
					XT	0.778	0.734	0.690	0.653	0.642	0.635	0.637	0.634	0.632	0.656	---
	6,4 3 Flute	0,25 3 Flute	19	0,75	Cv	0.0562	0.0725	0.101	0.146	0.216	0.312	0.433	0.588	0.802	1.07	0.90
					Kv	0.049	0.063	0.087	0.126	0.187	0.270	0.375	0.509	0.694	0.926	---
					XT	0.692	0.648	0.639	0.625	0.600	0.586	0.597	0.613	0.620	0.624	---

1. At 100% travel

## M-Flow - Flow Up – Mark EZ, Equal Percentage Characteristic

Valve Size, NPS	Port Diameter		Maximum Travel		Angle "A" of Flat	Flow Coefficient	Valve Opening- Percent of Total Travel										FL (1)
	mm	in.	mm	in.			10	20	30	40	50	60	70	80	90	100	
All Sizes 1 1-1/2 2	4,8	0,1875	19	0,75	1_55'	Cv	0.015	0.020	0.024	0.028	0.034	0.041	0.048	0.056	0.066	0.075	0.89
						Kv	0.013	0.017	0.021	0.024	0.029	0.035	0.042	0.048	0.057	0.065	---
						XT	0.964	0.888	0.906	0.947	0.942	0.928	0.949	0.947	0.918	0.934	---
					3_25'	Cv	0.016	0.026	0.038	0.052	0.070	0.088	0.107	0.127	0.153	0.181	0.84
						Kv	0.014	0.022	0.033	0.045	0.061	0.076	0.093	0.110	0.132	0.157	---
						XT	0.707	0.697	0.687	0.700	0.675	0.679	0.680	0.680	0.681	0.681	---

1. At 100% travel



Jordan Valve, a division of Richards Industries

3170 Wasson Road • Cincinnati, OH 45209

513.533.5600 • 800.543.7311 • 513.871.0105 (f)

info@richardsind.com • www.jordanvalve.com



Vinnova Exploration

sales@vinnova.asia

063-271-9119

www.vinnova.asia