

Mark 89/89MX Series

Three-Way Temperature Regulators

The Mark 89 is used for diverting service and is ideal for bypassing fluids around coolers or filters. In this configuration, there is one inlet and two outlets. As one inlet closes, the other outlet opens, diverting flow from one channel to the other.

The Mark 89MX is used as a combining or mixing valve with two inlets and one outlet. When used as a mixing valve, optimal performance will be achieved with equal pressures on both inlets.

FEATURES

- The Mark 89/89MX is a self-operated temperature regulating valve that features a three-way body for use on diverting service as a bypass valve (Mark 89) or for combining fluids as a mixing valve (Mark 89MX).
- Completely self-operated — no external power source required.
- Totally enclosed, heliarc welded stainless steel actuator for long service life — no gaskets or bellows to wear out.
- Thermal system with capillaries up to 100 feet (30 meters) in length are easily replaced in the field for quick range changes.
- Sliding gate seats provide —
 - Straight-through flow for reduced turbulence and quiet operation
 - Short stroke for fast response and accurate temperature control
 - Easily interchangeable Cv's
 - Tight shutoff



SPECIFICATIONS

Line Sizes: 1-1/2" (DN40) & 2" (DN50)

End Connections: NPT, BSPT, BSPP, Flanged

Body Materials:

- Carbon Steel (WCB)
- Stainless Steel (CF8M)

Trim Materials:

- 303 SS
- 316SS

Seat Materials:

- Jorcote on SST — Standard
- Other materials available — Consult factory

Yoke Material: Carbon Iron

Actuator: 304SS

Stem Packing Materials:

- Spring-loaded Teflon (to 450°F max/232°C max)
- Grafoil (above 500°F/260°C)

Service: steam, water, oil, gas, air and chemicals

Shutoff: ANSI Class IV

Body Rating: up to 1000 psi (69 bar) and 650°F (343,3 °C) depending on specific construction. -20°F (-28,9°C) temperature limit on all materials; for other temperatures, contact Jordan Valve.

Thermal System:

- Actuator Type: SWA
- Standard Capillary: 8' long Copper
- Standard Armor: SST
- Sensing Bulb: Copper (standard); SST (optional)
- Other Lengths and Materials available upon request
- Temperature Gauge: mounted on actuator as an option
- Thermal Wells (optional): Type A (standard): to fit bulb with 1" NPT trunk fitting; Type B Flanged: to fit bulb with 1-1/2" (DN40) or 2" (DN50) x 150# or 300# flange.

Flow Paths:

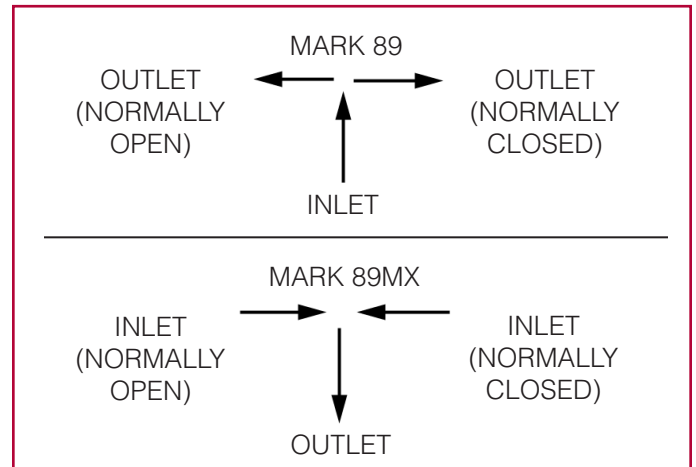

Cv Flow Coefficients & Maximum Differential Pressures

Size		Flow Coefficient		Seat Material	Maximum ΔP	
					Sat. Steam, Liquid Air	
Inches	DN	Cv	Kv		PSI	BAR
1-1/2" & 2"	40 & 50	15	12,9	Standard	40	2,8
		25	21,5			
		30	25,8	Jorcote	70	4,8

Note: Low flow trim available, consult factory for values.

SPECIFICATIONS

Available Temperature Control Ranges & Spans

Range °F (°C)	Thermal Fill	Temperature Span from closed to open °F (°C) with standard spring
-20 to 20 * (-29 to -7)	Freon 22	17 (9)
10 to 55 (-12 to 13)	Freon R134A	17 (9)
35 to 90 (2 to 32)	Iso Butane	18 (10)
55 to 115 (13 to 46)	N-Butane	18 (10)
80 to 140 (27 to 60)	Ethyl Chloride	18 (10)
110 to 165 (43 to 74)	Freon R123	26 (14)
120 to 185 (49 to 85)	Ethyl Ether	26 (14)
160 to 225 (71 to 107)	Acetone	26 (14)
205 to 260 (96 to 127)	Isopropyl Alcohol	17 (9)
230 to 290 (110 to 143)	N-Propyl Alcohol	18 (10)
265 to 325 (129 to 163)	N-Butyl Alcohol	18 (10)
315 to 400 (157 to 204)	M-Xylene	21 (12)
380 to 450 (193 to 232)	P-Cymene	21 (12)

* Required reinforced actuator

MAXIMUM WORKING PRESSURE & TEMPERATURE

Maximum Pressure @ 100°F, PSI (37,8°C, BAR)						
Packing	CS Body			SST Body		
	150#	300#	TE	150#	300#	TE
All	285 (19,6)	740 (51,0)	1000 (68,9)	275 (19,0)	720 (49,6)	1000 (68,9)
Pressure @ Maximum Temperature, PSI/°F (BAR/°C)						
TEF	170/500 (11,7/260)	600/500 (41,4/260)	1000/500 (68,9/260)	170/500 (11,7/260)	480/500 (33,1/260)	955/500 (65,8/260)
GRAF	125/650 (8,6/343)	535/650 (36,9/343)	1000/650 (68,9/343)	125/650 (8,6/343)	445/650 (30,7/343)	890/650 (61,4/343)

DIMENSIONS

Valve Dimensions

- Threaded Ends: MK89 & 89MX

Size	Dimensions (inches)				Weight (lbs.)
	A	B	C	D	
1-1/2"	7.12	12.75	3.75	7.0	38
2"	7.12	12.75	3.75	7.0	38

- Threaded Ends: MK89 & 89MX, DIN

Size (DN)	Dimensions (mm)				Weight (kg)
	A	B	C	D	
40	181	324	95	178	17
50	181	324	95	178	17

- Flanged Ends: MK89 & 89MX

Size	ANSI Flange	Dimensions (inches)				Weight (lbs.)
		A1	B	C1	D	
1-1/2"	150#	11.00	12.75	6.00	7.0	44
	300#	11.00	12.75	6.00	7.00	50
2"	150#	11.00	12.75	6.00	7.0	48
	300#	11.00	12.75	6.00	7.0	52

- Flanged Ends: MK89 & 89MX, DIN

Size (DN)	Flange (PN)	Dimensions (mm)				Weight (kg)
		A1	B	C1	D	
40	10/16	279	324	152	178	20
	25/40	279	324	152	178	23
50	10/16	279	324	152	178	22
	25/40	279	324	152	178	24

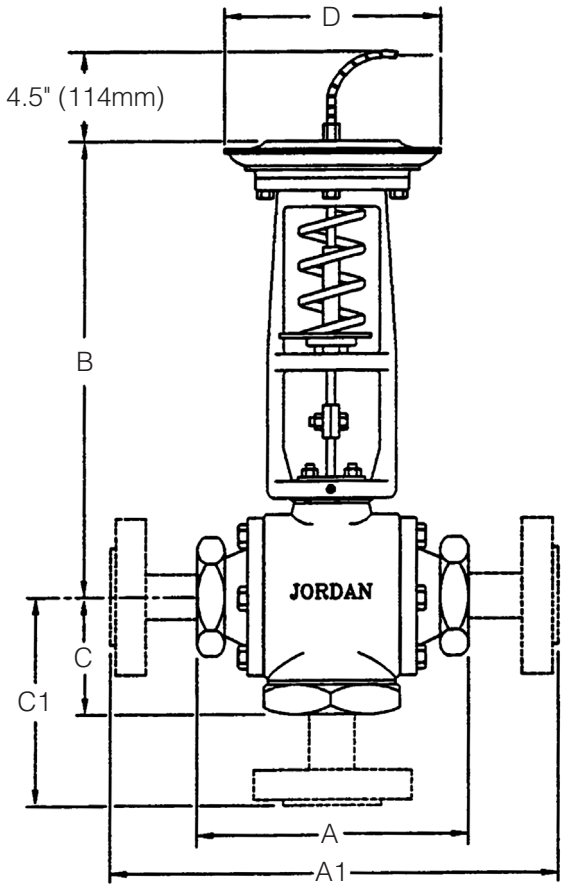

Bulb Dimensions

Bulb Type	Nom. Bulb Size (diameter x length)* for ranges beginning	
	101°F (38,3°C) or above	100°F (37,8°C) or below
A & B	1" x 12" (25,4mm x 304,8mm)	1" x 14" (25,4mm x 355,6mm)
C	1" x 12" (SST only) 25,4mm x 304,8mm	1" x 14" (25,4mm x 355,6mm)
	1-1/8" x 14" (Copper only) (28,6mm x 355,6mm)	1-1/8" x 14" (Copper only) (28,6mm x 355,6mm)
D-E-F	1" x 12" (25,4mm x 304,8mm)	1" x 14" (25,4mm x 355,6mm)

Consult factory for insertion length and special bulb lengths.

MARK 89/89MX THREE-WAY TEMPERATURE REGULATORS

ORDERING SCHEMATIC

1	—	2	—	3	/	4	5	6	7	8	9	10
----------	---	----------	---	----------	---	----------	----------	----------	----------	----------	----------	-----------

1	Model	
89	Three-Way Temperature Regulator	
89T	with Temperature Gage	
89MX	Three-Way Mixing Valve	
89MXT	with Temperature Gage	

2	Size	
	Inches	DN
150	1-1/2"	DN50
200	2"	DN50

3	Body Material	
CS	Carbon Steel (WCB)	
S6	Stainless Steel (CF8M)	

4	End Connections	
PT	NPT	
BP	BSPT	
BP	BSPP	
SW	FSW	
F5	150# FE (except IFE)	
F3	300# FE (except IFE)	

5	Trim	
T3	303 SS	
T6	316 SS	

6	Seats				
	Material	Cv	Kv		
A	303SST	9	15	12,9	
B	316 SST	A	25	21,5	
V	303SS/Jorcote	B	30	25,8	
W	316SS/Jorcote				

7	Range			
	Standard Spring °F		Standard Spring °C	
06	-20 – 20*	A6	-29 – 7*	
12	10 – 55	B2	-12 – 10	
19	35 – 90	B9	2 – 32	
27	55 – 115	C7	13 – 46	
35	80 – 140	D5	27 – 60	
42	110 – 165	E2	43 – 74	
49	120 – 185	E9	49 – 85	
58	160 – 225	F8	71 – 107	
66	205 – 260	G6	96 – 127	
72	230 – 290	H2	110 – 143	
81	265 – 325	J1	129 – 163	
88	315 – 400	J8	157 – 204	
93	380 – 450	K3	193 – 232	
	Light Spring °F		Light Spring °C	
05	-25 – -5	A5	-32 – -21	
11	5 – 35	B1	-15 – 2	
17	30 – 70	B7	-1 – 21	
24	50 – 90	C4	10 – 32	
32	75 – 115	D2	24 – 46	
41	105 – 140	E1	41 – 60	
46	115 – 160	E6	46 – 71	
58	155 – 200	F6	68 – 93	
64	195 – 235	G4	91 – 113	
71	225 – 270	H1	107 – 132	
79	260 – 300	H9	127 – 149	

* Required reinforced actuator

8	Thermowell			
	Type, Fitting & Material		Size for Bulb Diameter x Length	
A	Type A, 1" NPT Cu		A	1" x 12" (24,5mm x 304,8mm)
B	Type A, 1" NPT, SST		B	1" x 14" (24,5mm x 355,6mm)
E	Type B, 1-1/2" x 150#, SST			
F	Type B, 1-1/2" x 300#, SST			
G	Type B, 2" x 150#, SST			
H	Type B, 2" x 300#, SST			
Tank Fitting Only				
11	1" NPT Brass for 1" Bulb			
12	1" NPT SST for 1" Bulb			
NN	None			

ORDERING SCHEMATIC (CONT'D)

9	Thermowell System				
		Bulb Refer to the standard bulb dimensions chart for metrics	Cap/Arm ft (m)	Actuator	
	N1N1Q	1" x 12"	8 (2,4)	SWA	
	N2N1Q	1" x 14"	8 (2,4)		
	A1A2A	1" x 12"	10 (3,1)		
	A2A2A	1" x 14"	10 (3,1)		
	A1A3A	1" x 12"	12 (3,7)		
	A2A3A	1" x 14"	12 (3,7)		
	A1A4A	1" x 12"	15 (4,6)		
	A2A4A	1" x 14"	15 (4,6)		
	A1A5A	1" x 12"	20 (6,1)		
	A2A5A	1" x 14"	20 (6,1)		
	A2A1R	1" x 14"	8 (2,4)		Reinforced SWA
	A2A2R		10 (3,1)		
	A2A3R		12 (3,7)		
	A2A4R		15 (4,6)		
	A2A5R		20 (6,1)		
	Q1N1Q	1" x 12"	8 (2,4)	SWA	
	Q2N1Q	1" x 14"	8 (2,4)		
	G1B2A	1" x 12"	10 (3,1)		
	G2B2A	1" x 14"	10 (3,1)		
	G1B3A	1" x 12"	12 (3,7)		
	G2B3A	1" x 14"	12 (3,7)		
	G1B4A	1" x 12"	15 (4,6)		
	G2B4A	1" x 14"	15 (4,6)		
	G1B5A	1" x 12"	20 (6,1)		
	G2B5A	1" x 14"	20 (6,1)		
	G2B1R	1" x 14"	8 (2,4)		Reinforced SWA
	G2B2R		10 (3,1)		
	G2B3R		12 (3,7)		
	G2B4R		15 (4,6)		
	G2B5R		20 (6,1)		
	H1B1A	1" x 12"	8 (2,4)	SWA	
	H2B1A	1" x 14"	8 (2,4)		
	H1B2A	1" x 12"	10 (3,1)		
	H2B2A	1" x 14"	10 (3,1)		
	H1B3A	1" x 12"	12 (3,7)		
	H2B3A	1" x 14"	12 (3,7)		
	H1B4A	1" x 12"	15 (4,6)		
	H2B4A	1" x 14"	15 (4,6)		
	H1B5A	1" x 12"	20 (6,1)		
	H2B5A	1" x 14"	20 (6,1)		

9	Thermowell System				
		Bulb Refer to the standard bulb dimensions chart for metrics	Cap/Arm ft (m)	Actuator	
	H2B1R	1" x 14"	8 (2,4)	Reinforced SWA	
	H2B2R		SST Type B		10 (3,1)
	H2B3R		12 (3,7)		
	H2B4R		15 (4,6)		
	H2B5R		20 (6,1)		
	J3T1A	1" x 17"	8 (2,4)	SWA	
	J3T4A		TFE Coated Type B		10 (3,1)
	J3T5A		12 (3,7)		
	C9A1A	1-1/8" x 14"	8 (2,4)	SWA	
	C9A2A		Copper Type C		10 (3,1)
	C9A3A		12 (3,7)		
	C9A4A		15 (4,6)		
	C9A5A	20 (6,1)			
	C1B1A	1" x 12"	8 (2,4)	SWA	
	C1B2A		SST Type C		10 (3,1)
	C1B3A		12 (3,7)		
	C1B4A		15 (4,6)		
	C1B5A		20 (6,1)		
	C2B1A	1" x 14"	8 (2,4)	SWA	
	C2B2A		SST Type C		10 (3,1)
	C2B3A		12 (3,7)		
	C2B4A		15 (4,6)		
	C2B5A		20 (6,1)		

ORDERING SCHEMATIC (CON'T)

10	Accessories	
	0	None
	2	316SS Bolting
	6	Mtg. Flg. Cu 'C' Bulb
	7	Mtg. Flg. SST 'C' Bulb
	8	Yoke Cover (Flexible Neoprene)
	P	Thermometer in Position 1
	Q	Thermometer in Position 2
	R	Thermometer in Position 3
	S	Thermometer in Position 4
	T	Thermometer in Position 5
	U	Thermometer in Position 6
	V	Thermometer in Position 7
	W	Thermometer in Position 8
	X	Oxygen Clean
	Y	Oil-Free Clean
	Z	Non-Standard

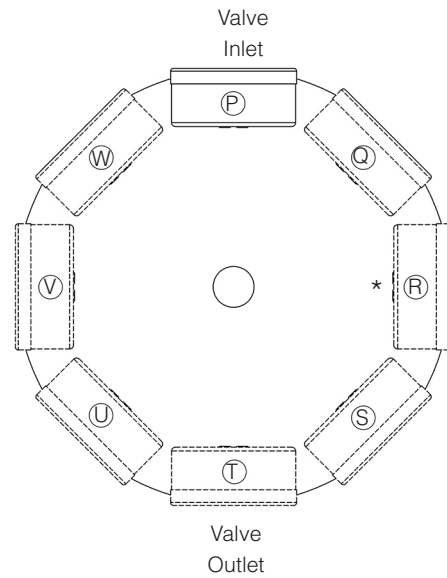

* Default Position if no selection