

# Mark 687 Series

## Piloted Soft Seat Regulator

The main valve of the Mark 687 is normally closed. The upstream pressure (P1) enters the main valve body and passes through the piping to the pilot valve. The pilot valve is normally open, allowing the upstream pressure to move through the outlet port of the pilot valve to act on the bottom of the main valve diaphragm. This force pushes the stem upward, opening the main valve. As the downstream pressure rises to the setpoint, the pilot senses the rising pressure and begins to close. This throttles the flow to the main diaphragm. The pressure on the main valve diaphragm is bled off downstream and the main valve closes. In this way, the Mark 687 modulates between open and closed to maintain control.



### SPECIFICATIONS

**Sizes:** 1-1/2" (DN40) through 2" (DN50)

#### End Connections

- Threaded — FNPT, BSPT, BSPP
- ANSI Flanges — 150#, 300#
- DIN Flanges — PN10/16, PN25/40
- Others available upon request

#### Body Materials

- Carbon Steel — ASME SA216 WCB
- Stainless Steel — ASME SA351 CF8M

**Trim Material:** 316SS/PTFE (Standard on all valves)

**Seat Material:** 316SS/PTFE

#### Actuator Materials

- Carbon Steel for WCB bodies
- Electroless Nickel Plated Carbon Steel for CF8M bodies

**Diaphragm Material:** Buna-N

**Service:** Water, oil, gas, air and chemicals

**Shutoff:** ANSI Class VI

#### Available Spring Ranges

- MK69L Low Pressure Pilot: 2-8, 5-30, 15-50 psi; 0,14-0,55; 0,34-2,1; 1,0-3,5 bar  
Note: MK69L pilot is limited to a differential of 50 psi (3,4 bar)
- MK69H High Pressure Pilot: 25-75, 70-150 psi; 1,7-5,2; 4,8-10,3 bar

**Minimum & Maximum Pressure Drop:** 25 psi minimum (1,7 bar); 150 psi maximum (10,3 bar)

**Pressure Temperature Ratings:** Maximum inlet 175 psi @ 100°F; 175 psi @ 275°F (12,1 bar @ 37,8°C; 121bar @ 135°C)

#### Flow Coefficients

- 1-1/2" Valves: 45 Cv
- 2" Valves: 45 Cv



Jordan Valve a division of Richards Industries  
3170 Wasson Road • Cincinnati, OH 45209  
513.533.5600 • 800.543.7311 • 513.871.0105 (f)  
info@richardsind.com • www.jordanvalve.com



Vinnova Exploration  
sales@vinnova.asia  
063-271-9119  
www.vinnova.asia

**DIMENSIONS**

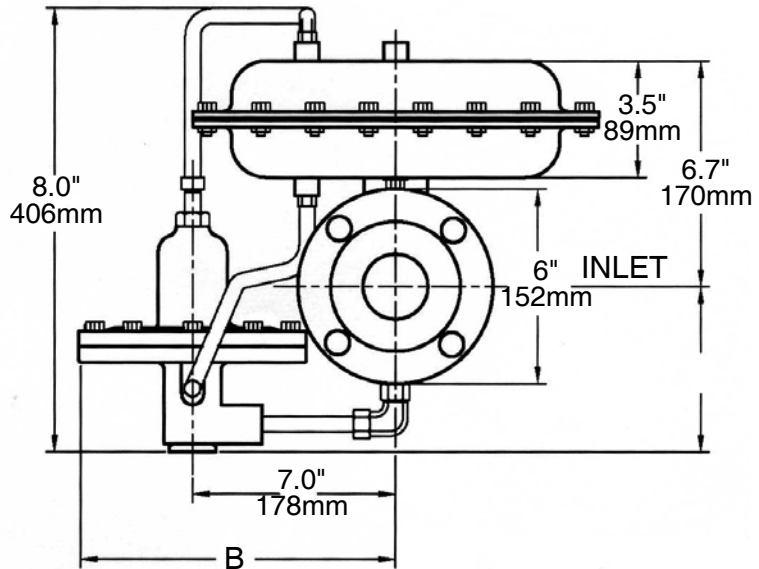
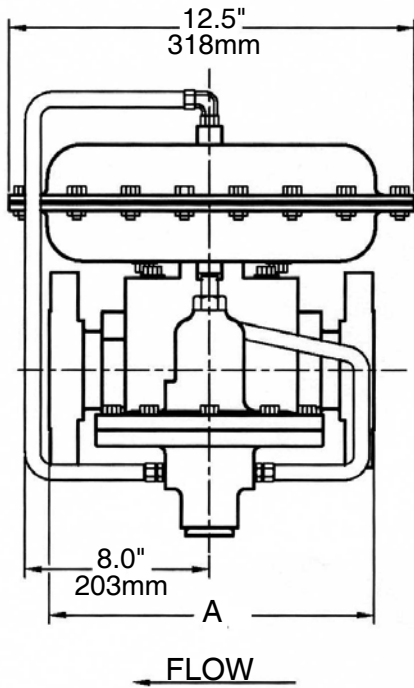

**INCHES**

Valve Size	Ends	A	Pilot	B	Weight lbs
1-1/2"	NPT	6.75	69H	9.1	75
	150#	8.75	69L	10.5	
	300#	9.25			
2"	NPT	6.75	69H	9.1	75
	150#	10.00	69L	10.5	
	300#	10.50			

**METRIC**

Valve Size	Ends	A	Pilot	B	Weight kgs
DN40	NPT	171,5	69H	231,1	34,1
	150#	222,3	69L	266,7	
	300#	235,0			
DN50	NPT	171,5	69H	231,1	34,1
	150#	254,0	69L	266,7	
	300#	266,7			

**ORDERING SCHEMATIC**

Model No	Size	Body Mat'l	1	2	3	4	5	6	7	8

687	Model
	Standard

150	200	Size
		1-1/2"
		2"

CS	S6	Body Material
		Carbon Steel (WCB)
		Stainless Steel (CF8M)

PT	BT	BP	SW	I5	I3	ZZ	1 & 2	End Connections
								NPT
								BSPT
								BSPP
								FSW
								150# FE
								300# FE
								Non-Standard

3 & 4	Trim
Plug Seat & Cage O-Ring Material / Cv	
HW	316 - TFE 45 Cv
ZZ	Non-Standard

5 & 6	Range
69L Pilot	
AA	2-8 (0,14-0,55)
34	5-30 (0,34-2,1)
AH	10-50 (1,0-3,5)
ZZ	Non-Standard
69H Pilot	
65	25-75 (1,7-5,2)
99	70-150 (4,8-10,3)
ZZ	Non-Standard

7 & 8	Accessories
00	None
S6	316SS Bolting
ZZ	Non-Standard