

Mark 63/64 Series

Differential Pressure Regulators

The Jordan Mark 63 is designed to maintain a constant differential between the pressure on the discharge side of the regulator and the signal pressure loaded on the diaphragm. The Mark 64 provides the same flow capacity as the Mark 63 but with less offset in controlled pressure due to a larger diaphragm.

The Mark 63CDF features a flow-through spring housing that is designed to permit "in-oil-line" installation. This is especially desirable where air or steam is used for fuel oil atomization. The fuel oil flow through the spring housing reduces the possibility of the oil asphaltting on top of the diaphragm which would cause a loss of differential pressure control and operating sensitivity. For added protection in this service, the Mark 63CDF includes a separated double diaphragm that prevents the fluid from mixing in the event that the diaphragm were to rupture.

The regulator is normally open. The outlet pressure acts beneath the diaphragm and is opposed by the force of the adjusting spring plus the pressure of the loading medium. As the outlet pressure overcomes the combined pressures on top of the diaphragm, the regulator moves to the closed position.

FEATURES

- Mark 63/64 — maintains a constant differential between the pressure on the discharge side of the regulator and the signal pressure loaded on the diaphragm. The MK64 features a larger effective diaphragm area for greater sensitivity.
- Mark 63CDF — features a flow-through spring housing for use in controlling atomizing steam or air to oil burners.
- Sliding Gate Seats — all of Jordan Valve's differential regulators feature advanced sliding gate seat technology: straight-through flow for reduced turbulence and quiet operation; short stroke for fast response and accurate regulation; easily interchangeable Cv's; tight shutoff



SPECIFICATIONS

Sizes: (Note: 1/4" (DN8) & 3/8"(DN12) use 1/2" (DN15) body with reducer bushings)

- Mark 63: 1/4" (DN8) through 2" (DN50)
- Mark 64: 1/4" (DN8) through 3/4" (DN20)
- Mark 63: 2-1/2" (DN65) through 4" (DN100) - Consult factory

End Connections:

- Threaded — FNPT, BSPT, BSPP
- ANSI Flanges — 150#, 300#
- DIN Flanges — PN10/16, PN25/40

Body Materials:

- Ductile Iron
- Bronze
- Carbon Steel — A216 WCB
- Stainless Steel — SA351 CF8M

Trim Materials:

- 303 SST — Standard on Ductile Iron, Bronze, or Carbon Steel valves
- 316SST — Standard on Stainless Steel valves

Seat Materials:

- Jorcote on SST - standard
- Other materials available - consult factory



Jordan Valve, a division of Richards Industrials

3170 Wasson Road • Cincinnati, OH 45209

513.533.5600 • 800.543.7311

jordan@richardsind.com • www.jordanvalve.com



Vinnova Exploration

sales@vinnova.asia

063-271-9119

www.vinnova.asia

SPECIFICATIONS (CONT'D)

Diaphragm Materials

- Stainless Steel - Standard (450°F (232°C) temp limit)
- Buna-Nitrile (200°F (93°C) temp limit)
- Viton (450°F (232°C) temp limit)
- Jorlon (450°F (232°C) temp limit)

Spring Housing Materials: Ductile Iron (standard)
Contact Factory for other materials

Service: Steam, oil, gas, air, chemicals, and water

Shutoff: ANSI Class IV

Body Rating:

Body Matl.	End Conn.	-20 to 100°F	200°F	300°F	400°F	500°F	600°F	650°F
DI	T.E.	300 (600)	300 (600)	300 (600)	300 (600)	300 (600)	300 (600)	300 (600)
	150#FE	250	235	215	200	170	140	125
	300#FE	600	600	600	525	495	465	450
	600#FE	600	600	600	600	600	600	600
BRZ	T.E.	300 (500)	300 (475)	300 (425)	300 (375)	300 (325)	N/A	N/A
	150#FE	225	215	195	170	150	N/A	N/A
	300#FE	500	475	425	375	325	N/A	N/A
CS	T.E.	300 (950)	300 (950)	300 (950)	300 (950)	300 (950)	300 (950)	300 (950)
	150#FE	285	260	230	200	170	140	125
	300#FE	740	675	665	635	600	550	535
	600FE	950	950	950	950	950	950	950
SS	T.E.	300 (950)	300 (950)	300 (950)	300 (950)	300 (950)	300 (905)	300 (890)
	150#FE	275	240	215	195	170	140	125
	300#FE	720	620	560	515	480	450	445
	600#FE	950	950	950	950	950	905	890

Note: Double bolting option is required to reach pressures indicated in parenthesis (). For temperatures below -20°F or above 650°F, consult factory

Note: To convert temperature to Celsius: subtract Fahrenheit temperature by 32, multiply result by 5, divide answer by 9, final answer to temperature in Celsius ((F-32)*5/9 = C). To convert PSI to BAR, divide by 14.5.

Maximum Dome Loading Pressure: the combined pressure of the spring setting (psig) and dome loading (psig) must not exceed the body rating.

Options:

- C: Adjusting screw closing cap on spring housing: plain (no bleed port); with Accessory 03, bleed port with valve; or with Accessory 04, bleed port plugged.
- *CD: Closing cap/separated double diaphragm
- CDF: Closing cap/separated double diaphragm and flow thru dome
- CF: Closing cap/flow thru dome
- *H: Handwheel and packing box
- F: Flow-through spring housing. Permits "in-oil-line" installation for fuel oil atomization and steam atomizing systems. Reduces the possibility of the oil asphaltting on top of the diaphragm

Options (continued):

- *D: Separated double diaphragm (prevents mixing fluids in case of ruptured diaphragm)
- DF: Double diaphragm/flow thru
- HP: High pressure spring housing
- H: Handwheel and packing box
- HF: Handwheel/flow thru dome
- HDF: Handwheel, double diaphragm/flow thru dome

* Available for Mark 63 and 64. Other options only available for Mark 63.

Differential Pressure Control Ranges, PSI (BAR)

Model	Size	Ranges in psi (bar)		
MK63	1/4" - 3/4" (DN8 - 20)	2-23 (0,14-1,6)	10-38 (0,7-2,6)	20-55 (1,4-3,8)
		35-160 (2,4-11)	95-220 (6,6-15)	30-85 (2,1-5,8)
	1" - 2" (DN25 - DN50)	1-5 (0,07-0,34)	3-8 (0,21-0,55)	5-20 (0,34-1,4)
		10-30 (0,7-2,1)	20-45 (1,4-3,1)	30-95 (2,1-6,6)
		60-160 (4,1-11)		
	MK63HP	1/2" - 2" (DN15-25)	75-190 (5,2-13)	100-320 (6,9-22)
MK64	1/4" - 3/4" (DN8-20)	1-5 (0,07-0,34)	2-12 (0,14-0,8)	2-25 (0,14-1,7)
		10-35 (0,7-2,4)	20-55 (1,4-3,8)	20-80 (1,4-5,5)
		40-115 (2,8-8)	25-160 (1,7-11)	30-180 (2,1-12)

Cv (Kv) Value & Maximum Differential Pressures

Cv (Kv)	Size (DN)	Seat Material	Max. ΔP PSI (bar)
0.84	1/4" (DN8)	Jorcote	400 (27,6)
1.6 (1,4)	3/8" (DN12)	Jorcote	400 (27,6)
2.5 (2,2)	1/2" & 3/4" (DN15 & DN20)	Jorcote	400 (27,6)
4.4 (3,8)			
6.4 (5,5)	1" & 1-1/4" (DN25 & DN32)	Jorcote	400 (27,6)
9.5 (8,2)			
15 (12,9)			
25 (21,5)	2" (DN50)	Jorcote	325 (22,4)
30 (25,8)			

*** Low Flow Trim:** reduced Cv's (Kv's) can be placed in any size valve as long as it is smaller than the standard Cv (Kv) for that particular size. In addition, the following special low flows can be provided:

1.6 (1,4)	0.84 (0,72)	0.42 (0,36)	0.21 (0,18)	0.08 (0,07)	0.04 (0,03)
0.02 (0,017)	0.008 (0,007)	0.004 (0,003)	0.002 (0,0017)	0.0008 (not in 316SS) (0,0007)	

MARK 63 SERIES DIMENSIONS

• Flanged Ends

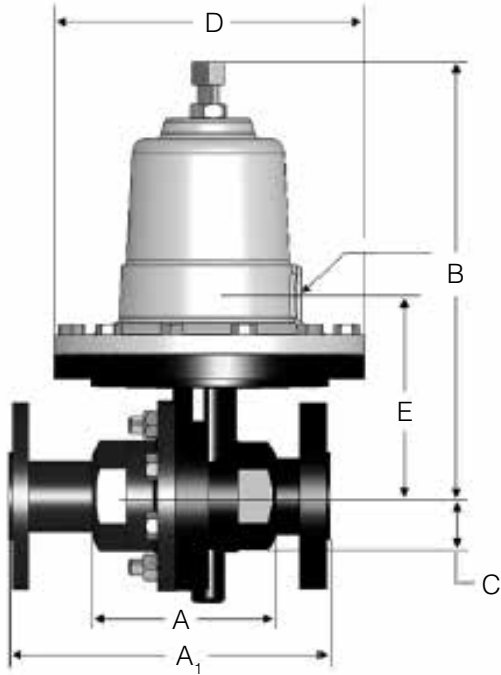

Size	ANSI Flange	Dimensions (inches)										Weight (lbs.)	
		A		B		C	D	E		DI/BRZ	CS/SS		
		DI/BRZ	CS/SS	DI/BRZ	CS/SS	All	All	DI/BRZ	CS/SS				
1/2"	150#	7.25	7.25	8.50	8.50	1.69	5.12	3.94	3.94	13	15		
	300#	7.50	7.50	8.50	8.50	1.69	5.12	3.94	3.94	14	16		
3/4"	150#	7.25	7.25	8.50	8.50	1.69	5.12	3.94	3.94	14	16		
	300#	7.52	7.62	8.50	8.50	1.69	5.12	3.94	3.94	16	17		
1"	150#	7.25	7.25	10.00	10.75	2.62	7.09	4.53	4.83	26	34		
	300#	8.75	7.75	10.00	10.75	2.62	7.09	4.53	4.83	28	37		
1-1/4"	150#	7.87	—	10.00	—	2.62	7.09	4.53	—	28	—		
	300#	8.37	—	10.00	—	2.62	7.09	4.53	—	31	—		
1-1/2"	150#	8.75	8.75	10.25	11.22	2.31	7.09	4.50	5.08	42	46		
	300#	10.25	9.25	10.25	11.22	2.31	7.09	4.50	5.08	45	52		
2"	150#	10.00	10.00	10.25	11.42	2.75	7.09	4.75	5.05	46	50		
	300#	10.50	10.50	10.25	11.42	2.75	7.09	4.75	5.05	49	55		

• Flanged Ends, DIN

Size (DN)	Flange (PN)	Dimensions (mm)										Weight (kg)	
		A		B		C	D	E		DI/BRZ	CS/SS		
		DI/BRZ	CS/SS	DI/BRZ	CS/SS	All	All	DI/BRZ	CS/SS				
15	10/16	184 ⁴	130	216	240	43	130	100	100 ¹	5,9	6,8		
	25/40	184 ⁴	130	216	240	43	130	100	100 ¹	6,4	7,3		
20	10/16	184 ⁴	150	216	240	43	130	100	100 ¹	6,4	7,3		
	25/40	184 ⁴	150	216	240	43	130	100	100 ¹	7,3	7,7		
25	10/16	184 ⁴	160	273	262	67	180	115	123 ²	11,8	15,4		
	25/40	184 ⁴	160	273	262	67	180	115	123 ²	12,7	16,8		
32	10/16	200 ⁴	—	273	—	67	180	115	—	12,7	—		
	25/40	200 ⁴	—	273	—	67	180	115	—	14,1	—		
40	10/16	222 ⁴	200	279	285	59	180	114	129 ¹	19,1	20,9		
	25/40	222 ⁴	200	279	285	59	180	114	129 ¹	20,9	23,6		
50	10/16	254 ⁴	230	279	290	70	180	120	128 ³	20,9	22,7		
	25/40	254 ⁴	230	279	290	70	180	120	128 ³	22,2	24,9		

• Threaded Ends

Size	Mat'l	Dimensions (inches)					Weight (lbs.)
		A	B	C	D	E	
1/2" & 3/4"	DI/BRZ	3.62	8.50	1.69	5.12	3.94	10
	CS/SS	3.62	8.50	1.69	5.12	3.94	12
1"	DI/BRZ	4.12	10.00	2.62	7.09	4.53	21
	CS/SS	4.18	10.75	2.62	7.09	4.83	25
1-1/4"	DI/BRZ	4.12	10.00	2.62	7.09	4.53	21
1-1/2"	DI/BRZ	4.50	10.25	2.31	7.09	4.50	23
	CS/SS	4.81	11.00	2.25	7.09	5.08	31
2"	DI/BRZ	4.50	10.25	2.75	7.09	4.72	26
	CS/SS	5.50	11.00	2.75	7.09	5.05	35

• Threaded Ends, DIN

Size (DN)	Mat'l	Dimensions (mm)					Weight (kg)
		A	B	C	D	E	
15 & 20	DI/BRZ	92	216	43	130	100	4,4
	CS/SS	92	216	43	130	100	5,4
25	DI/BRZ	105	254	67	180	115	9,5
	CS/SS	106	273	67	180	123	11,3
32	DI/BRZ	105	254	67	180	115	9,5
40	DI/BRZ	114	260	59	180	114	10,4
	CS/SS	122	279	57	180	129	14,0
50	DI/BRZ	114	260	70	180	120	11,8
	CS/SS	140	279	70	180	128	15,9

MARK 64 SERIES DIMENSIONS

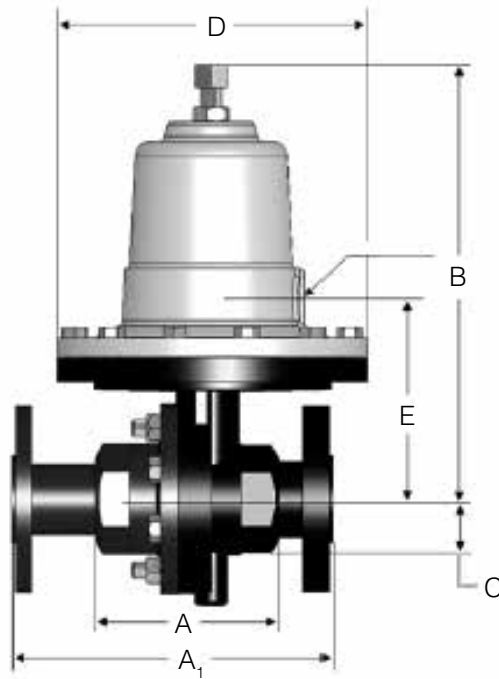

• Flanged Ends

Size	ANSI Flange	Dimensions (inches)								Weight (lbs.)	
		A		B		C	D	E			
		DI/BRZ	CS/SS	DI/BRZ	CS/SS	All	All	DI/BRZ	CS/SS	DI/BRZ	CS/SS
1/2"	150#	9.62	9.62	10.25	10.25	2.25	7.12	4.33	4.25	26	26
	300#	9.62	9.62	10.25	10.25	2.25	7.12	4.33	4.25	26	26
3/4"	150#	10.25	10.25	10.25	10.25	2.25	7.12	4.33	4.25	29	29
	300#	10.25	10.25	10.25	10.25	2.25	7.12	4.33	4.25	29	29

• Flanged Ends, DIN

Size (DN)	Flange (PN)	Dimensions (mm)								Weight (kg)	
		A		B		C	D	E			
		DI/BRZ	CS/SS	DI/BRZ	CS/SS	All	All	DI/BRZ	CS/SS	DI/BRZ	CS/SS
15	10/16	244	244	260	260	57	181	110	108	12	12
	25/40	244	244	260	260	57	181	110	108	12	12
20	10/16	260	260	260	260	57	181	110	108	6,4	13
	25/40	260	260	260	260	57	181	110	108	7,3	13

• Threaded Ends

Size	Mat'l	Dimensions (inches)					Weight (lbs.)
		A	B	C	D	E	
1/2"	DI/BRZ	3.62	10.25	2.25	7.12	4.33	12
	CS/SS	3.62	10.25	2.25	7.12	4.25	13
3/4"	DI/BRZ	3.62	10.25	2.25	7.12	4.33	12
	CS/SS	3.62	10.25	2.25	7.12	4.25	13

• Threaded Ends, DIN

Size (DN)	Mat'l	Dimensions (mm)					Weight (kg)
		A	B	C	D	E	
15	DI/BRZ	92	260	57,2	181	110	5,5
	CS/SS	92	260	57,2	181	110	5,5
20	DI/BRZ	92	260	57,2	181	108	5,9
	CS/SS	92	260	57,2	181	108	5,9

MARK 63/64 DIFFERENTIAL PRESSURE REGULATORS

ORDERING SCHEMATIC

Model	Options	Size	Body Material	/	1	2	3	4	5	6	7	8	9	10	11	12	13	14	15	

Model	
63	Standard
64	Large Diaphragm

Options	
*C	Closing Cap
*CD	Closing Cap/Separated DBL Diaphragm
CDF	Closing Cap/Separated DBL Diaphragm + Flow Thru Dome
CF	Closing Cap/Flow Thru Dome
*D	Separated Double Diaphragm
DF	Separated Double Diaphragm/Flow Thru Dome
F	Flow Thru Dome
*H	Handwheel
HF	Handwheel/Flow Thru Dome
HDF	Handwheel/Double Diaphragm/Flow Thru Dome
HP	High Pressure
* Available for Mark 63 and 64. Other options only available for Mark 63.	

Size	
025	1/4" (DN8)
038	3/8" (DN12)
050	1/2" (DN15)
075	3/4" (DN20)
100	1" (DN25)
125	1-1/4" (DN32)
150	1-1/2" (DN40)
200	2" (DN50)

Body Material	
DI	Ductile Iron
BR	Bronze
CS	Carbon Steel (WCB)
S6	Stainless Steel (CF8M)

1&2	End Connections
PT	NPT
BT	BSPT
BP	BSPP
SW	FSW
I5	150#IFE
F5	150#FE (Except IFE)
I3	300# IFE
F3	300#FE (Except IFE)
ZZ	Non-Standard

3&4	Trim
S3	303SS
S6	316SS
I3	303SS F/IFE (1/2" - 2")
I6	316SS F/IFE (1/2" -2")

5	Seat Material
A	303SST
B	316SST
Q	303SST/Teflon Coated
R	316SST/Teflon Coated
V	303SS/Jorcote
W	316SS/Jorcote

6	Cv	Kv
1	0.21	0,18
2	0.42	0,36
3	0.84	0,72
4	1.6	1,38
5	2.5	2,15
6	4.4	3,78
7	6.4	5,50
8	9.5	8,17
9	15	12,9
A	25	21,5
B	30	25,8

7&8	Range, PSI			
	MK63 1/4" - 3/4"		MK63 1" - 2"	
	15	2-20 SST	05	1-5
	16	2-23	07	2-6 SST
	37	10-38	20	3-8
	43	15-35 SST	13	2-16 SST
	56	20-55	28	5-20
	59	20-60 SST	33	10-25 SST
	D8	30-85	34	10-30
	74	30-85 SST	53	20-45
	81	35-160	75	30-95
	A6	95-220	97	60-160

ORDERING SCHEMATIC (CON'T)

Model	Options	Size	Body Material	/	1	2	3	4	5	6	7	8	9	10	11	12	13	14	15	

7&8	Range, psi			
	MK63HP		MK64	
	A1	75-190	05	1-5
	A7	100-320	10	2-12
	A9	150-450	11	2-12 SST
			17	2-25
			18	2-25 SST
			36	10-35
			B3	10-35 SST
			56	20-55
			57	20-55 SST
			63	20-80
			87	40-115
			70	25-160
			80	30-180

13&14	Double Bolting	
	00	None

15	Accessories	
	0	None
	6	316SS Bolting
	7	Hi-Temp Bolt
	3	Bleed Port with Valve (Mk63C only)
	4	Bleed Port Plugged (Mk63C only)
	Z	Non-Standard

9&10	Diaphragm	
	S6	316 SST
	VI	Viton
	BN	Buna-N
	JL	Jorlon
	ZZ	Non-Standard

11&12	Actuator	
	MD	For Metal Diaphragm
	ED	For Elastomer Diaphragm
	ZZ	Non-Standard



Jordan Valve, a division of Richards Industrials
 3170 Wasson Road • Cincinnati, OH 45209
 513.533.5600 • 800.543.7311
 jordan@richardsind.com • www.jordanvalve.com



Vinnova Exploration
 sales@vinnova.asia
 063-271-9119
 www.vinnova.asia