

Mark 57 Series

CRN Registration Number Available

Externally Piloted Back Pressure Regulators

The Mark 57 provides accuracy that approaches that of controller-operated valves and should be considered on most critical applications before other costly, more sophisticated instrumentation.

The Mark 57 is part of the sliding gate regulator offering. As with all sliding gate products, a much shorter stroke than the standard globe or plug style valve is achieved. The shorter stroke combined with the action of the pilot valve creates a faster and more accurate response (less build-up). This allows a shorter travel for the seats to reach optimal positioning, with less diaphragm movement.

OPERATION

The Mark 57 main valve and pilot are normally closed. The inlet pressure passes through the inlet pilot tubing beneath the pilot diaphragm. When the setpoint is reached, the force of the adjusting spring is overcome and the pilot valve opens. This allows the inlet pressure to enter the chamber above the main diaphragm and opens the main valve. When the pressure drops below the setpoint, the adjusting spring overcomes the force of the pressure beneath the pilot diaphragm, and the pilot and main valve close.

Due to the piloted sliding gate design, one can expect enhanced control performance in the areas of droop and rangeability. Build-up for this valve will be in the 3 - 5% range. Rangeability can be as high as 50:1.

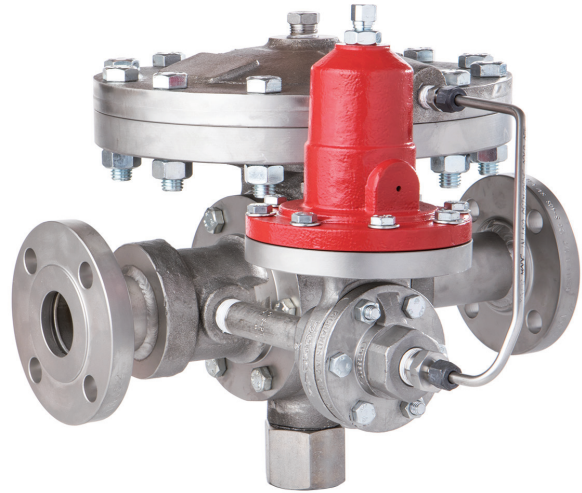

FEATURES

- High turn-down ratios – up to 50:1
- Sliding gate seats – Jordan Valve's pilot-operated regulators feature advanced sliding gate seat technology:
 - Straight-through flow for reduced turbulence
 - Short stroke for fast response and accurate regulation
 - Easily interchangeable Cv's and trim sets
 - Tight shutoff
- Versatile application – for use on steam, water, air, gas and chemicals



Jordan Valve a division of Richards Industries

3170 Wasson Road • Cincinnati, OH 45209
513.533.5600 • 800.543.7311 • 513.871.0105 (f)
jordan@richardsind.com • www.jordanvalve.com



Vinnova Exploration
sales@vinnova.asia
063-271-9119
www.vinnova.asia

SPECIFICATIONS

Line Sizes: 1/2" (DN15) through 6" (DN150)

End Connections

- Threaded – FNPT, BSPT, BSPP – 1/2" - 2" (DN15 - 50)
- Companion Flanges – 1/2" - 2" (DN15 - 50)
- Integral Flanges – 2-1/2" - 6" (DN65 - 150)

Body Materials

- Ductile Iron
- Cast Iron
- Carbon Steel – A216 WCB
- Stainless Steel – A351 CF8M

Trim Materials

- 303SS – Standard on DI, CI or CS valves
- 316SS – Standard on SS Valves

Seat Materials

- Jorcote on SST – Standard
- Other materials available – Consult factory

Bolting Materials

- Grade B7 chromium- molybdenum alloy steel standard for all body and dome materials. Grades B8 (Type 304) or B8M (Type 316) stainless steel available as an option.

Diaphragm Material: Stainless Steel – standard

Service: Steam, water, oil, gas, air and chemicals

Shutoff: ANSI Class IV

Pressure Control Ranges, PSI (BAR)

10 - 30 (0,7 - 2,1)	20 - 45 (1,4 - 3,1)	30 - 135 (2,1 - 9,3)	80 - 185 (5,52 - 12,8)
------------------------	------------------------	-------------------------	---------------------------

Note: a minimum pressure differential of 25 psi from valve inlet to outlet is required for proper operation. Consult factory for set points below 25 psi.

Cv (Kv) Values & Maximum Differential Pressures:

Flow Coeff.		Valve Size (DN)	Seat Material	Max ΔP	
Cv	Kv			PSI	BAR
5	4,3	1/2" (DN15)	SST	125	8,6
			Jorcote	300	20,7
9.5	8,2	3/4" (DN20)	SST	12	8,6
			Jorcote	300	20,7
15	12,9	1" (DN25)	SST	75	5,2
			Jorcote	275	19,0
25	21,5	1-1/4" (DN32)	SST	75	5,2
			Jorcote	275	19,0
30	25,8	1-1/2" (DN40)	SST	75	5,2
			Jorcote	275	19,0
50	43	2" (DN50)	SST	75	5,2
			Jorcote	275	19,0
55	47,3	2-1/2" (DN65)	Jorcote	400	27,6
115	98,0	3" (DN80)	Jorcote	400	27,6
200	172	4" (DN100)	Jorcote	325	22,4
395	340	6" (DN150)	Jorcote	325	22,4

MAXIMUM WORKING PRESSURE & TEMPERATURE

Maximum Pressure @ 100°F, PSI/°F (Maximum Pressure @ 37,8°C, BAR, °C)														
Size	Bolt	Diaph.	DI Body			CI Body			CS Body			SST Body		
			150#	300#	TE	125#	250#	TE	150#	300#	TE	150#	300#	TE
1/4"-2" (DN8-50)	Std.	S6	250 (17)	300 (21)	300 (21)	200 (14)	300 (21)	300 (21)	285 (20)	300 (21)	300 (21)	275 (19)	300 (21)	300 (21)
	Dbf.	S6	250 (17)	600 (41)	600 (41)	200 (14)	500 (23)	500 (34)	285 (20)	740 (51)	950 (66)	275 (19)	720 (50)	950 (66)
2-1/2"-6" (DN65-150)	Std.	S6	250 (17)	300 (21)	—	200 (14)	300 (21)	—	285 (20)	300 (21)	—	275 (19)	300 (21)	—
	Dbf.	S6	250 (17)	500 (34)	—	200 (14)	500 (34)	—	285 (20)	500 (34)	—	275 (19)	500 (34)	—
Pressure @ Maximum Temperature, PSI/°F (BAR/°C)														
1/4"-2" (DN8-50)	Std.	S6	125/650 (9/343)	300/650 (21/343)	300/600 (21/343)	125/450 (9/232)	250/450 (17/232)	250/450 (17/232)	125/650 (9/343)	300/650 (21/343)	301/650 (21/343)	125/650 (9/343)	300/650 (21/343)	300/650 (21/343)
	Dbf.	S6	125/650 (9/343)	450/650 (31/343)	450/650 (31/343)	125/450 (9/232)	250/450 (17/232)	250/450 (17/232)	125/650 (9/343)	535/650 (37/343)	950/650 (66/343)	125/650 (9/343)	445/650 (31/343)	890/650 (61/343)
2-1/2"-6" (DN65-150)	Std.	S6	200/400 (14/204)	300/400 (21/204)	—	125/450 (9/232)	250/450 (17/232)	—	125/650 (9/343)	300/650 (21/343)	—	125/650 (9/343)	300/650 (21/343)	—
	Dbf.	S6	200/400 (14/204)	525/400 (36/204)	—	125/450 (9/232)	250/450 (17/232)	—	125/650 (9/343)	535/650 (37/343)	—	125/650 (9/343)	445/650 (31/343)	—

MARK 57 EXTERNALLY PILOTED BACK PRESSURE REGULATORS

DIMENSIONS

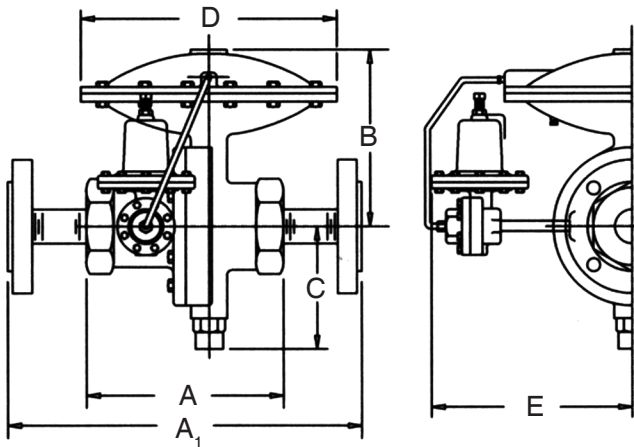

MK57 (1/2" – 2")

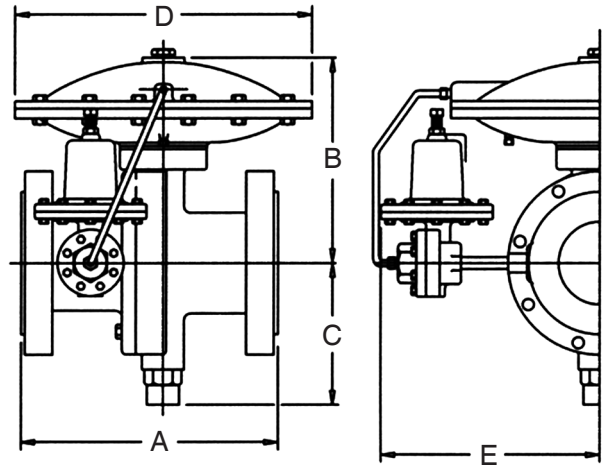

MK57 (2-1/2" – 6")

THREADED & FSW ENDS

Valve Size	Dimensions (inches)						Weight Lbs
	A		B	C	D	E	
	DI	CS/SS	ALL	ALL	ALL	ALL	
1/2"	5.31	5.50	5.06	3.50	7.12	11.38	31
3/4"	5.31	5.50	5.06	3.50	7.12	11.38	37
1"	5.69	6.50	5.25	3.62	7.12	11.50	42
1-1/4"	5.88	6.50	5.43	3.75	7.12	11.62	42
1-1/2"	8.18	8.18	7.00	5.00	10.62	11.88	74
2"	8.18	8.18	7.00	5.00	10.62	11.88	76

THREADED & FSW ENDS, METRIC

Valve Size	Dimensions (mm)						Weight Kgs
	A		B	C	D	E	
	DI	CS/SS	ALL	ALL	ALL	ALL	
DN15	135	140	129	89	181	289	14,1
DN20	135	140	129	89	181	289	16,8
DN25	145	165	133	92	181	292	19,1
DN32	149	165	138	95	181	295	19,1
DN40	208	208	178	127	270	302	33,6
DN50	208	208	178	127	270	302	34,5

FLANGED ENDS 150# & 300#

Valve Size	Dimensions (inches)					Weight Lbs
	A	B	C	D	E	
1/2"	11.50	5.06	3.50	7.12	11.38	35
3/4"	11.50	5.06	3.50	7.12	11.38	43
1"	11.50	5.25	3.62	7.12	11.50	48
1-1/4"	11.50	5.43	3.75	7.12	11.62	50
1-1/2"	14.50	7.00	5.00	10.62	11.88	86
2"	14.50	7.00	5.00	10.62	11.88	90

FLANGED ENDS PN 10/16/25/40, METRIC

Valve Size	Dimensions (mm)					Weight Kgs
	A	B	C	D	E	
DN15	292	129	89	181	289	15,9
DN20	292	129	89	181	289	19,5
DN25	292	133	92	181	292	21,8
DN32	292	138	95	181	295	22,7
DN40	368	178	127	270	302	39,0
DN50	368	178	127	270	302	40,8

Valve Size	Dimensions (inches)						Weight Lbs
	Flange Rating	A	B	C	D	E	
2-1/2"	125-150	10.87	10.68	6.93	12.75	14.00	173
	250-300	11.50					
3"	125-150	11.75	10.68	6.93	12.75	14.00	193
	250-300	12.50					
4"	125-150	13.87	11.88	8.00	12.75	15.00	223
	250-300	14.50					
6"	125-150	17.75	12.57	9.00	12.75	15.00	313
	250-300	18.62					

Valve Size	Dimensions (mm)						Weight Kgs
	Flange PN	A ₁	B	C	D	E	
DN65	10/16	287	271	176	324	356	78,5
	25/40	293					
DN80	10/16	313	271	176	324	356	87,5
	25/40	313					
DN100	10/16	353	302	203	324	381	101,2
	25/40	353					
DN150	10/16	474	319	229	324	381	142,0
	25/40	474					

Not per DIN3202

MARK 57 EXTERNALLY PILOTED BACK PRESSURE REGULATORS

ORDERING SCHEMATIC

Model No	Size	Body Mat'l	/	1	2	3	4	5	6	7	8	9	10	11	12	13	14	15

Model	
57	Standard

Size	
050	1/2" (DN15)
075	3/4" (DN20)
100	1" (DN25)
125	1-1/4" (DN32)
150	1-1/2" (DN40)
200	2" (DN50)
250	2-1/2" (DN65)
300	3" (DN80)
400	4" (DN100)
600	6" (DN150)

Body Material	
DI	Ductile Iron
CS	Carbon Steel (WCB)
S6	Stainless Steel (CF8M)
CI	Cast Iron

4		End Connections	
1/2" - 2" Size Range			
	PT	NPT	
	BP	BSPT	
	BP	BSPP	
	SW	FSW	
	F5	150#FE	
	F3	300#FE	
	F1	125#FE	
	F2	250#FE	
2-1/2" - 6" Size Range			
	I5	150#IFE CS, S6, or DI	
	I3	300#IFE CS, S6, or DI	
	I1	125#IFE CI	
	I2	250#IFE CI	
	I7	IFE PN10, all materials	
	I6	IFE PN16, all materials	
	I8	IFE PN25, all materials	
	I4	IFE PN40, all materials	

3 & 4		Trim	
S3		303SS	
S6		316SS	
L3		303SS LO-DP 15	
L4		316SS LO-DP 15	
L5		303SS LO-DP 20	
L6		316SS LO-DP 20	
ZZ		Non-Standard	

5		Seats	
A		303SST	
B		316SST	
Q		303SST/Teflon Coated	
R		316SST/Teflon Coated	
V		303SS/Jorcote	
W		316SS/Jorcote	
X		303SS/Jorcote/Jordanic	
Y		316SS/Jorcote/Jordanic	

6		Cv's (Kv's)				
		Cv	Kv		Cv	Kv
K		5.0	4,3	C	50	43,1
8		9.5	8,2	D	55	47,4
9		15	12,9	G	115	99,1
A		25	21,6	I	200	172,4
B		30	25,9	J	395	340,5
V		35	30,2	Z	Non-Standard	

7 & 8		Range	
34		10 - 30 (0,7 - 2,1)	
53		20 - 45 (1,4 - 3,1)	
76		30 - 135 (2,1 - 9,3)	
A4		80 - 185 (5,5 - 12,8)	
ZZ		Non-Standard	

9 & 10		Diaphragm	
S6		316SST	

11 & 12		Actuator	
MD		For Metal Diaphragm	



Jordan Valve a division of Richards Industries
 3170 Wasson Road • Cincinnati, OH 45209
 513.533.5600 • 800.543.7311 • 513.871.0105 (f)
 info@richardsind.com • www.jordanvalve.com



Vinnova Exploration
 sales@vinnova.asia
 063-271-9119
 www.vinnova.asia