

Mark 53/54 Series

Differential Back Pressure Regulators

The Jordan Mark 53 maintains a constant differential between the inlet pressure and the pressure loaded on top of the diaphragm. It can be used for both differential and remotely adjusted applications. The Mark 54 provides the same flow capacity as the Mark 53 but with less offset in controlled pressure due to larger diaphragm.

The valve is normally closed. The inlet pressure acts beneath the diaphragm and is opposed by the force of the adjusting spring plus the pressure of the loading fluid. As the inlet pressure overcomes the set point (the combined pressures on top of the diaphragm), the valve moves toward the open position, relieving the necessary pressure to maintain the set point.



FEATURES

- Mark 53/54 — maintains a constant differential between the inlet pressure and the pressure loaded to the top of the diaphragm.
- Sliding Gate Seats — all of Jordan Valve's differential regulators feature advanced sliding gate seat technology.
 - Straight-through flow for reduced turbulence and quiet operation
 - Short stroke for fast response and accurate regulation
 - Easily interchangeable Cv's
 - Tight Shutoff

SPECIFICATIONS

Sizes: (Note: 1/4" (DN8) & 3/8"(DN12) use 1/2"(DN15) body with reducer bushings)

- Mark 53/53HP: 1/4" (DN8) through 2" (DN50)
- Mark 54: 1/4" (DN8) through 3/4" (DN20)

End Connections:

- Threaded — FNPT, BSPT, BSPP
- ANSI Flanges — 150#, 300#
- DIN Flanges — PN10/16, PN25/40

Body Materials:

- Ductile Iron
- Bronze
- Carbon Steel — A216 WCB
- Stainless Steel — SA351 CF8M

Trim Materials:

- 303 SST — Standard on Ductile Iron, Bronze, or Carbon Steel valves
- 316SST — Standard on Stainless Steel valves

Seat Materials:

- Jorcote on SST – Standard
- Other materials available – Consult factory



Jordan Valve, a division of Richards Industries
 3170 Wasson Road • Cincinnati, OH 45209
 513.533.5600 • 800.543.7311 • 513.871.0105 (f)
 info@richardsind.com • www.jordanvalve.com



Vinnova Exploration
 sales@vinnova.asia
 063-271-9119
 www.vinnova.asia

SPECIFICATIONS (CONT'D)

Diaphragm Materials

- Stainless Steel - Standard (450°F (232°C) temp limit)
- Buna-Nitrile (200°F (93°C) temp limit)
- Viton (450°F (232°C) temp limit)
- Jorlon (450°F (232°C) temp limit)

Spring Housing Materials: Ductile Iron

Service: Steam, oil, gas, air, chemicals, and water

Shutoff: ANSI Class IV

Body Rating:

Body Matl.	End Conn.	-20 to 100°F	200°F	300°F	400°F	500°F	600°F	650°F
DI	T.E.	300 (600)	300 (600)	300 (600)	300 (600)	300 (600)	300 (600)	300 (600)
	150#FE PN20	250	235	215	200	170	140	125
	300#FE PN50	300 (600)	300 (600)	300 (600)	300 (525)	300 (495)	300 (465)	300 (450)
	600#FE PN100	300 (600)	300 (600)	300 (600)	300 (600)	300 (600)	300 (600)	300 (600)
BRZ	T.E.	300 (500)	300 (475)	300 (425)	300 (375)	300 (325)	N/A	N/A
	150#FE PN20	225	215	195	170	150	N/A	N/A
	300#FE PN50	300 (500)	300 (475)	300 (425)	300 (375)	300 (325)	N/A	N/A
CS	T.E.	300 (950)	300 (950)	300 (950)	300 (950)	300 (950)	300 (950)	300 (950)
	150#FE PN20	285	260	230	200	170	140	125
	300#FE PN50	300 (740)	300 (675)	300 (665)	300 (635)	300 (600)	300 (550)	300 (535)
	600FE PN100	300 (950)	300 (950)	300 (950)	300 (950)	300 (950)	300 (950)	300 (950)
SS	T.E.	300 (950)	300 (950)	300 (950)	300 (950)	300 (950)	300 (905)	300 (890)
	150#FE PN20	275	240	215	195	170	140	125
	300#FE PN50	300 (720)	300 (620)	300 (560)	300 (515)	300 (480)	300 (450)	300 (445)
	600#FE PN100	300 (950)	300 (950)	300 (950)	300 (950)	300 (950)	300 (905)	300 (890)

Note: Double bolting option is required to reach pressures indicated in parenthesis (). For temperatures below -20°F or above 650°F, consult factory

Note: To convert temperature to Celsius: subtract Fahrenheit temperature by 32, multiply result by 5, divide answer by 9, final answer to temperature in Celsius ((F-32)*5/9 = C). To convert PSI to BAR, divide by 14.5.

Maximum Dome Loading Pressure: the combined pressure of the spring setting (psig) and dome loading (psig) must not exceed the body rating.

Options:

- DB: Double bolting for higher pressure ratings
- C: Closing cap for adjusting screw
- B: Bleed valve on spring housing (available only with option C closing cap above)
- H: Handwheel and packing box
- F: Flow-through spring housing. Permits "in-oil-line" installation for fuel oil atomization and steam atomizing systems. Reduces the possibility of the oil asphaltting on top of the diaphragm
- D: Separated double diaphragm (prevents mixing fluids in case of ruptured diaphragm)
- HP: High pressure spring housing
- H: Handwheel and packing box

Differential Pressure Control Ranges, PSI (BAR)

Model	Size	Ranges in psi (bar)		
MK53	1/4" - 3/4" (DN8 - 20)	2-20 (0,14-1,39)	10-30 (0,69-2,07)	20-45 (1,38-3,10)
		30-135 (2,07-9,31)	80-185 (5,52-12,76)	
	1" - 2" (DN25 - DN50)	1/2-4 (0,03-0,28)	2-6 (0,14-0,41)	4-13 (0,28-0,90)
		8-20 (0,55-1,38)	15-80 (1,03-5,52)	45-150 (3,10-10,34)
MK53HP	1/2" - 2" (DN15-25)	75-190 (5,17-13,10)	100-320 (6,89-22,06)	150-450 (10,34-31,03)
MK54	1/4" - 3/4" (DN8-20)	1/2-5 (0,03-0,34)	2-10 (0,14-0,69)	2-20 (0,14-1,38)
		10-30 (0,60-2,07)	20-50 (1,38-3,45)	20-70 (1,38-4,83)
		40-105 (2,76-7,24)	25-150 (1,72-10,34)	30-170 (2,07-11,72)

Cv (Kv) Value & Maximum Differential Pressures

Cv (Kv)	Size (DN)	Seat Material	Max. ΔP PSI (bar)
0.84 (0,74)	1/4" (DN8)	Jorcote	400 (27,6)
1.6 (1,4)	3/8" (DN12)	Jorcote	400 (27,6)
2.5 (2,2)	1/2" & 3/4" (DN15 & DN20)	Jorcote	400 (27,6)
4.4 (3,8)			
6.4 (5,5)	1" & 1-1/4" (DN25 & DN32)	Jorcote	400 (27,6)
9.5 (8,2)			
15 (12,9)	1-1/2" (DN40)	Jorcote	325 (22,4)
25 (21,5)	2" (DN50)	Jorcote	325 (22,4)
30 (25,8)			

* **Low Flow Trim:** reduced Cv's (Kv's) can be placed in any size valve as long as it is smaller than the standard Cv (Kv) for that particular size. In addition, the following special low flows can be provided:

1.6 (1,38)	0.84 (0,72)	0.42 (0,36)	0.21 (0,18)	0.08 (0,07)	0.04 (0,03)
0.02 (0,017)	0.008 (0,007)	0.004 (0,003)	0.002 (0,0017)	0.0008 (not in 316SS) (0,0007)	

MARK 53 SERIES DIMENSIONS

• Flanged Ends

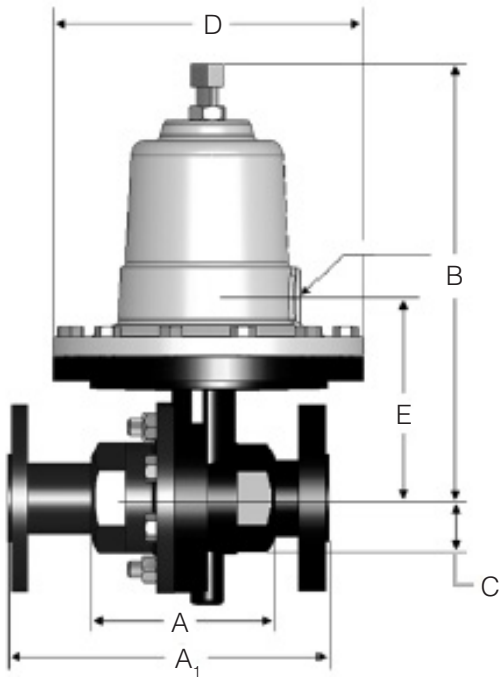

Size	ANSI Flange	Dimensions (inches)										Weight (lbs.)	
		A		B		C	D	E		DI/BRZ	CS/SS		
		DI/BRZ	CS/SS	DI/BRZ	CS/SS	All	All	DI/BRZ	CS/SS				
1/2"	150#	7.25	7.25	8.50	8.50	1.69	5.12	3.94	3.94	13	15		
	300#	7.50	7.50	8.50	8.50	1.69	5.12	3.94	3.94	14	16		
3/4"	150#	7.25	7.25	8.50	8.50	1.69	5.12	3.94	3.94	14	16		
	300#	7.52	7.62	8.50	8.50	1.69	5.12	3.94	3.94	16	17		
1"	150#	7.25	7.25	10.00	10.75	2.62	7.09	4.53	4.83	26	34		
	300#	8.75	7.75	10.00	10.75	2.62	7.09	4.53	4.83	28	37		
1 1/4"	150#	7.87	—	10.00	—	2.62	7.09	4.53	—	28	—		
	300#	8.37	—	10.00	—	2.62	7.09	4.53	—	31	—		
1 1/2"	150#	8.75	8.75	10.25	11.22	2.31	7.09	4.50	5.08	42	46		
	300#	10.25	9.25	10.25	11.22	2.31	7.09	4.50	5.08	45	52		
2"	150#	10.00	10.00	10.25	11.42	2.75	7.09	4.75	5.05	46	50		
	300#	10.50	10.50	10.25	11.42	2.75	7.09	4.75	5.05	49	55		

• Flanged Ends, DIN

Size (DN)	Flange (PN)	Dimensions (mm)										Weight (kg)	
		A		B		C	D	E		DI/BRZ	CS/SS		
		DI/BRZ	CS/SS	DI/BRZ	CS/SS	All	All	DI/BRZ	CS/SS				
15	10/16	184 ⁴	130	216	240	43	130	100	100 ¹	5,9	6,8		
	25/40	184 ⁴	130	216	240	43	130	100	100 ¹	6,4	7,3		
20	10/16	184 ⁴	150	216	240	43	130	100	100 ¹	6,4	7,3		
	25/40	184 ⁴	150	216	240	43	130	100	100 ¹	7,3	7,7		
25	10/16	184 ⁴	160	273	262	67	180	115	123 ²	11,8	15,4		
	25/40	184 ⁴	160	273	262	67	180	115	123 ²	12,7	16,8		
32	10/16	200 ⁴	—	273	—	67	180	115	—	12,7	—		
	25/40	200 ⁴	—	273	—	67	180	115	—	14,1	—		
40	10/16	222 ⁴	200	279	285	59	180	114	129 ¹	19,1	20,9		
	25/40	222 ⁴	200	279	285	59	180	114	129 ¹	20,9	23,6		
50	10/16	254 ⁴	230	279	290	70	180	120	128 ³	20,9	22,7		
	25/40	254 ⁴	230	279	290	70	180	120	128 ³	22,2	24,9		

• Threaded Ends

Size	Mat'l	Dimensions (inches)					Weight (lbs.)
		A	B	C	D	E	
1/2" & 3/4"	DI/BRZ	3.62	8.50	1.69	5.12	3.94	10
	CS/SS	3.62	8.50	1.69	5.12	3.94	12
1"	DI/BRZ	4.12	10.00	2.62	7.09	4.53	21
	CS/SS	4.18	10.75	2.62	7.09	4.83	25
1 1/4"	DI/BRZ	4.12	10.00	2.62	7.09	4.53	21
1 1/2"	DI/BRZ	4.50	10.25	2.31	7.09	4.50	23
	CS/SS	4.81	11.00	2.25	7.09	5.08	31
2"	DI/BRZ	4.50	10.25	2.75	7.09	4.72	26
	CS/SS	5.50	11.00	2.75	7.09	5.05	35

• Threaded Ends, DIN

Size (DN)	Mat'l	Dimensions (mm)					Weight (kg)
		A	B	C	D	E	
15 & 20	DI/BRZ	92	216	43	130	100	4,4
	CS/SS	92	216	43	130	100	5,4
25	DI/BRZ	105	254	67	180	115	9,5
	CS/SS	106	273	67	180	123	11,3
32	DI/BRZ	105	254	67	180	115	9,5
40	DI/BRZ	114	260	59	180	114	10,4
	CS/SS	122	279	57	180	129	14,0
50	DI/BRZ	114	260	70	180	120	11,8
	CS/SS	140	279	70	180	128	15,9

MARK 54 SERIES DIMENSIONS

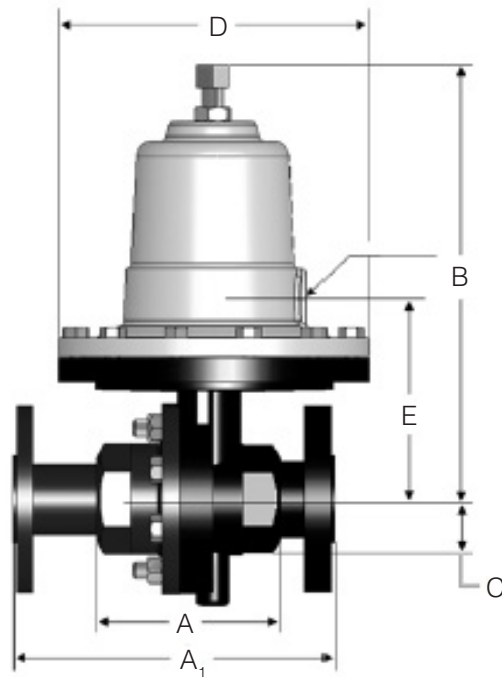

• Flanged Ends

Size	ANSI Flange	Dimensions (inches)										Weight (lbs.)	
		A		B		C	D	E					
		DI/BRZ	CS/SS	DI/BRZ	CS/SS	All	All	DI/BRZ	CS/SS	DI/BRZ	CS/SS		
1/2"	150#	9.62	9.62	10.25	10.25	2.25	7.12	4.33	4.25	26	26		
	300#	9.62	9.62	10.25	10.25	2.25	7.12	4.33	4.25	26	26		
3/4"	150#	10.25	10.25	10.25	10.25	2.25	7.12	4.33	4.25	29	29		
	300#	10.25	10.25	10.25	10.25	2.25	7.12	4.33	4.25	29	29		

• Flanged Ends, DIN

Size (DN)	Flange (PN)	Dimensions (mm)										Weight (kg)	
		A		B		C	D	E					
		DI/BRZ	CS/SS	DI/BRZ	CS/SS	All	All	DI/BRZ	CS/SS	DI/BRZ	CS/SS		
15	10/16	244	244	260	260	57	181	110	108	12	12		
	25/40	244	244	260	260	57	181	110	108	12	12		
20	10/16	260	260	260	260	57	181	110	108	6,4	13		
	25/40	260	260	260	260	57	181	110	108	7,3	13		

• Threaded Ends

Size	Mat'l	Dimensions (inches)					Weight (lbs.)
		A	B	C	D	E	
1/2"	DI/BRZ	3.62	10.25	2.25	7.12	4.33	12
	CS/SS	3.62	10.25	2.25	7.12	4.25	13
3/4"	DI/BRZ	3.62	10.25	2.25	7.12	4.33	12
	CS/SS	3.62	10.25	2.25	7.12	4.25	13

• Threaded Ends, DIN

Size (DN)	Mat'l	Dimensions (mm)					Weight (kg)
		A	B	C	D	E	
15	DI/BRZ	92	260	57,2	181	110	5,5
	CS/SS	92	260	57,2	181	110	5,5
20	DI/BRZ	92	260	57,2	181	108	5,9
	CS/SS	92	260	57,2	181	108	5,9

ORDERING SCHEMATIC

To specify a MK53/54 Differential Back Pressure Regulator, build a model number by making a selection from each category in the Product Designator Coding System below.

1	2	3	4	5	6	7	8	9	10

1	Model	
53	Standard	
54	Large Diaphragm	

2	Options	
C	Closing Cap	
D	Separated Double Diaphragm	
F	Flow Through Dome	
H	Handwheel	
HP	High Pressure	

3	Size	
025	1/4" (DN8)	
038	3/8" (DN12)	
050	1/2" (DN15)	
075	3/4" (DN20)	
100	1" (DN25)	
125	1-1/4" (DN32)	
150	1-1/2" (DN40)	
200	2" (DN50)	

4	Body Material			
DI	Ductile Iron	CS	Carbon Steel	
BR	Bronze	S6	Stainless Steel	

5	End Connections	
PT	NPT	
BT	BSPT	
BP	BSPP	
SW	FSW	
I5	150#IFE CS or SST valves	
I3	300#IFE CS or SST Valves	
F5	150#IFE DI or BR	
F3	300#IFE DI or BR	
I7	IFE PN10	
I6	IFE PN16	
I8	IFE PN25	
I4	IFE PN40	

6	Trim			
S3	303SS	I3	303SS F/IFE (1/2"-2")	
S6	316SS	I6	316SS F/IFE (1/2"-2")	

7	Seat Material			
A	303SST	V	303SS/Jorcote	
B	316SST	W	316SST/Jorcote	
Q	303SST/Teflon Coated	R	316SST/Teflon Coated	

8	Cv		Kv	
1	0.21		0,18	
2	0.42		0,36	
3	0.84		0,72	
4	1.6		1,38	
5	2.5		2,15	
6	4.4		3,78	
7	6.4		5,50	
8	9.5		8,17	
9	15		12,9	
A	25		21,5	
B	30		25,8	

9	Range, PSI			
	MK53 1/4" - 3/4"		MK53 1" - 2"	
14	2-20		03	1/2-4
34	10-30		06	2-6
53	20-45		21	4-13
76	30-135		31	8-20
A4	80-185		50	15-80
			95	45-150
	MK53HP 1/2" - 2"		MK54	
A3	75-190		04	1/2-5
A7	100-320		08	2-10
A9	150-450		14	2-20
			34	10-30
			54	20-50
			62	20-70
			86	40-105
			69	25-150
			79	30-170

10	Diaphragm	
S6MD	316SST	
VIED	Viton	
BNED	Buna-N	
JLED	Jorlon	



Jordan Valve, a division of Richards Industries
 3170 Wasson Road • Cincinnati, OH 45209

513.533.5600 • 800.543.7311 • 513.533.5600
 info@richardsindustries.com • www.richardsindustries.com
VINNOVA EXPLORATION
 sales@vinnova.asia
 063-271-9119
www.vinnova.asia