

Mark 33 Series

Electric Motor Control Valves

The Mark 33 is a motor operated valve featuring the Jordan sliding gate seat and heavy-duty industrial motors for proportional (resistance), on-off, 4-20mA electronic control. Models include the Mark 33 in sizes 1/4" through 2" (DN8 through DN50), the high flow Mark 331/332 with Cv's up to 70 *60 Kv), and the Mark 39 with three-way body.

The Mark 33 delivers exceptional pressure drop capabilities due to the short stroke of the sliding gate seat which permits greater utilization of the motor torque output. Power is transmitted via a cam (instead of gears), allowing the valve to handle higher than usual pressure drop conditions. The 24 VAC 50/60 Hz Honeywell actuators are split-phase, capacitor-type enclosed in a gasketed die-cast magnesium housing that is rated NEMA 3.

The Mark 331/332 electric motor operated control valves feature high capacities in relation to line size. With Cv's up to 70 (60 Kv) in a 2" (DN50) valve, the Mark 331/332 combines the superior accuracy of the sliding gate seat design with the heavy-duty Honeywell electric motor for reliable, long-term operation.

FEATURES

- Heavy-duty industrial grade motor:
 - Die-cast magnesium housing
 - NEMA 3 (weather protection) rated
 - UL® listed and CSA approved
 - Oil emmersed motor and gear train for long-term, reliable performance
- Sliding Gate Seats — features advanced sliding gate seat technology.
 - Straight-through flow reduces turbulence for long life, quiet operation and excellent rangeability
 - Short stroke for fast response and accurate regulation.
 - Interchangeable seats for easy maintenance and Cv changes
 - Tight Shutoff (ANSI Class IV) due to overlap of seat closure area

CRN Registration Number Available

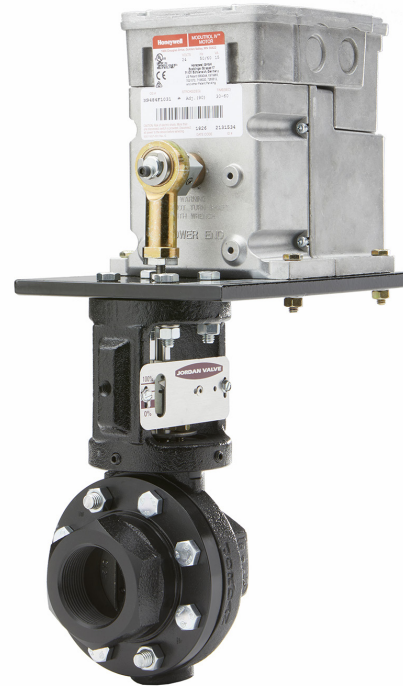

SPECIFICATIONS

Sizes

- MK33: 1/4" through 2" (DN8 through DN50)
Note: 1/4" & 3/8" sizes uses 1/2" body with reducers
- MK331/332: 1-1/2" & 2" (DN40 & DN50)

End Connections

- Threaded
- Flanged

Body Materials:

- Ductile Iron
- Bronze
- Carbon Steel
- Stainless Steel

Trim Materials:

- 303SS for DI, BZ or CS body valves
- 316SS for SS body valves

Seat Materials:

- Jorcote on SST — Standard
- Chrome Plated SST — Optional



Jordan Valve, a division of Richards Industries
3170 Wasson Road • Cincinnati, OH 45209
513.533.5600 • 800.543.7311 • 513.871.0105 (f)
jordan@richardsind.com • www.jordanvalve.com



Vinnova Exploration
sales@vinnova.asia
063-271-9119
www.vinnova.asia

SPECIFICATIONS (CON'T)

Packing: Spring loaded Teflon (to 500°F/260°C); braided (above 500°F/260°C)

Service: steam, water, air, oil, gas and chemicals

Shutoff: ANSI Class IV

Seat Interchangeability MK331/332: 1-1/2" with 2" (DN40 with DN50)

Power Requirements: 24 VAC, 50/60 Hz (optional transformer required for 120 VAC)

Command Signals: proportional control (0-135 ohms); on-off control; current command (4-12, 4-20, 12-20 mA DC standard); voltage command 2-10 VDC

Operating Time (approximate): 30 seconds

Ambient Temperature Limit for Motors: -40°F to 150°F (4,4°C to 66°C)

Options

- Spring return: for controlled failure in the open or closed position; regardless of valve action
- Transformer: for operation on 120 VAC
- Stem position indicator: shows stem motion and valve position between open and closed

Loading Effect for Electric Control

Control Signal (mA DC)	Net Loading Effect on mA Controller (ohms)*
4 - 12	67
4 - 20	67
12 - 20	67

Caution: Check controller literature to be certain that the controller is compatible with the loading.

Cv (Kv) Ratings and Maximum Allowable ΔP:

Mark 33

Cv (Kv)	Valve Size	Seat Material	Max ΔP, psi (bar)
2.5 (2,15)	1/4" to 3/4"	SST	175 (12,1)
4.4 (3,8)	(DN8 to 20)	Jorcote	550 (38)
6.4 (5,5)	1" & 1-1/4"	SST	150 (10,3)
9.5 (8,2)		Jorcote	350 (24)
15 (13)	1-1/2" (DN40)	SST	125 (8,6)
		Jorcote	275 (19)
25 (22)	2" (DN50)	SST	125 (8,6)
30 (26)		Jorcote	275 (19)

*** Low Flow Trim Available:** reduced Cv's (Kv's) can be used in a valve of any size as long as the required flow is a smaller value than the standard Cv (Kv) for the particular size. In addition, the following Cv's (Kv's) can be provided.

1.6 (1,4)	0.84 (0,72)	0.42 (0,36)	0.21 (0,18)
0.08 (0,07)	0.04 (0,03)	0.02 (0,017)	0.008 (0,007)
0.004 (0,003)	0.002 (0,002)	0.0008 (N/A in 316SS) (0,00069)	

High Flow MK331

Cv (Kv)	Valve Size	Seat Material	Max ΔP, psi (bar)
25 (26)	1-1/2" & 2" (DN40 & 50)	SST	50 (3,5)
		Jorcote	225 (16)
45 (39)	1-1/2" (DN40)	SST	50 (3,5)
		Jorcote	225 (16)
50 (43)	2" (DN50)	SST	50 (3,5)
		Jorcote	225 (16)

High Flow MK332

Cv (Kv)	Valve Size	Seat Material	Max ΔP, psi (bar)
65 (56)	1-1/2" (DN40)	Jorcote	90 (6,2)
70 (60)	2" (DN50)	Jorcote	90 (6,2)

Maximum Working Pressure & Temperature

Maximum Pressure @ 100°F (38°C), PSI/°F (Bar/°C)												
Packing	DI Body			BRZ Body			CS Body			SST Body		
	150#	300#	TE	150#	300#	TE	150#	300#	TE	150#	300#	TE
Any	250/100 (72/38)	640/100 (44/38)	988/100 (68/38)	225/100 (16/38)	500/100 (34/38)	500/100 (34/38)	285/100 (20/38)	740/100 (51/38)	1480/100 (102/38)	275/100 (19/38)	720/100 (50/38)	1440/100 (99/38)
Pressure @ Maximum Temperature, PSI/°F (Bar/°C)												
TEF	170/500 (12/260)	495/500 (34/260)	808/500 (56/260)	150/500 (10/260)	325/500 (22/260)	325/500 (22/260)	170/500 (12/260)	600/500 (41/260)	1200/500 (83/260)	170/500 (12/260)	480/500 (33/260)	955/500 (66/260)
GRAF	125/500 (9/260) 125/650* (9/343)	450/650 (31/343)	715/650 (49/343)	150/500 (10/260)	325/500 (22/260)	325/500 (22/260)	125/500 (9/260) 125/650* (9/343)	535/650 (37/343)	1075/650 (74/343)	125/650 (9/343)	445/650 (31/343)	890/650 (61/343)

* Mark 331/332 only

DIMENSIONS

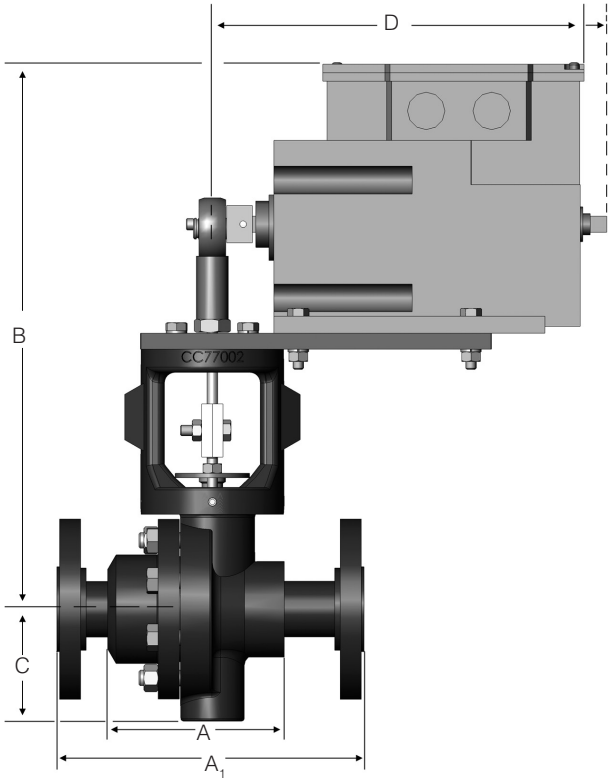

• Flanged Ends

Size	ANSI Flange	Dimensions (inches)				Weight (lbs.)
		A1	B	C	D	
1/2"	150#	7.25	12.95	2.18	7.50	19
	300#	7.50	12.95	2.18	7.50	21
3/4"	150#	7.25	12.95	2.18	7.50	21
	300#	7.62	12.95	2.18	7.50	23
1"	150#	7.25	13.20	2.62	7.50	24
	300#	7.75	13.20	2.62	7.50	26
1-1/4"	150#	7.87	13.20	2.62	7.50	24
	300#	8.37	13.20	2.62	7.50	28
1-1/2"	150#	8.75	13.45	2.75	7.50	27
	300#	9.25	13.70	2.75	7.50	33
2"	150#	10.00	13.45	3.00	7.50	32
	300#	10.50	13.61	3.00	7.50	36

• Flanged Ends, Metric

Size	Flange (PN)	Dimensions (mm)				Weight (kgs)
		A1	B	C	D	
15	10/16	184	329	55	191	8,6
	25/40	191	329	55	191	9,5
20	10/16	184	329	55	191	9,5
	25/40	194	329	55	191	10,4
25	10/16	184	335	67	191	10,9
	25/40	197	335	67	191	11,8
32	10/16	200	335	67	191	10,9
	25/40	213	335	67	191	12,7
40	10/16	222	342	70	191	12,2
	25/40	235	348	70	191	15,0
50	10/16	254	342	76	191	14,5
	25/40	267	346	76	191	16,3

• Threaded Ends

Size	Material	Dimensions (inches)				Weight (lbs)
		A	B	C	D	
1/2" & 3/4"	DI/BRZ	3.62	12.95	2.12	7.50	17
	CS/SS	3.65	12.95	2.18	7.50	17
1"	DI/BRZ	4.12	13.20	2.62	7.50	20
	CS/SS	4.25	13.20	2.62	7.50	20
1-1/4"	DI/BRZ	4.12	13.20	2.62	7.50	20
1-1/2"	DI/BRZ	4.50	13.45	2.62	7.50	21
	CS/SS	4.65	13.70	2.75	7.50	21
2"	DI/BRZ	4.50	13.45	2.62	7.50	22
	CS/SS	5.50	13.61	3.00	7.50	22

• Threaded Ends, Metric

Size	Flange (PN)	Dimensions (mm)				Weight (kgs)
		A	B	C	D	
15 & 20	DI/BRZ	91,9	329	55	190,5	7,4
	CS/SS	93,0	329	55	190,5	7,4
25	DI/BRZ	108	335	67	190,5	8,7
	CS/SS	108	335	67	190,5	8,7
32	DI/BRZ	108	335	67	190,5	8,7
40	DI/BRZ	114	342	67	190,5	9,5
	CS/SS	118	348	70	190,5	9,5
50	DI/BRZ	114	342	67	190,5	10
	CS/SS	140	346	76	190,5	10

ORDERING SCHEMATIC

Model No	Size	Body Mat'l	1	2	3	4	5	6	7	8	9	10	11	12	13	14	15

Model	
33	Standard
331	High Flow
332	Super High Flow

Size	
025*	1/4" (DN8)
038*	3/8" (DN12)
050*	1/2" (DN15)
075*	3/4" (DN20)
100*	1" (DN25)
125*	1-1/4" (DN32) (DI and BR only)
150	1-1/2" (DN40)
200	2" (DN50)

Material	
DI	Ductile Iron
BR	Bronze
CS	Carbon Steel (WCB)
S6	Stainless Steel (CF8M)

1 & 2 End Connections			
PT	NPT	F5	150# FE (except IFE)
BT	BSPT	I2	250# IFE
BP	BSPP	F2	250# FE (except IFE)
SW	FSW	I3	300# IFE
I1	125# FE	F3	300# FE (except IFE)
F1	125# FE (except IFE)	ZZ	Non-Standard
I5	150# IFE		

3 & 4 Trim	
T3	303SS/Teflon Packing
T6	316SS/Teflon Packing
I3	303SS/Graphite Packing
I6	316SS/Graphite Packing
ZZ	Non-Standard

5 Seat Materials	
A	303SST
B	316SST
V	303SS/Jorcote
W	316SS/Jorcote

6	Cv (Kv)		
1*	0.21 (0,18)	9	15 (12,9)
2*	0.42 (0,36)	A	25 (21,5)
3*	0.84 (0,72)	B	30 (25,8)
4*	1.6 (1,38)	V**	35 (30,2)
5*	2.5 (2,16)	W**	45 (38,8)
6*	4.4 (3,78)	C**	50 (43,1)
7	6.4 (5,51)	Y**	65 (56,0)
8	9.5 (8,18)	E**	70 (68,8)

7 & 8	Range
RE	Resistance (0 - 135 ohm)
NF	On-Off
42	4-20 mA
41	4-12 mA
12	12-20 mA
ZZ	Non-Standard

9 & 10	Actuator
1L	Standard 1 L.S.
2L	Standard 2 L.S.
R1	Spring Return 1 L.S.
R2	Spring Return 2 L.S.
ZZ	Non-Standard

11 & 12	Accessories
00	None
TS	Travel Scale
TR	Transformer 120 VAC
SR	Travel Scale & 120V Transformer
FE	Feedback Pot 1-135 ohm
ZZ	Non-Standard

13 & 14	Action
DD	Direct
RR	Reverse

For Spring Return	
DP	Direct Fail Open
DC	Direct Fail Close
RP	Reverse Fail Open
RC	Reverse Fail Close

15	PED Compliance
0	Not required
F	CE Category 1

* Mark 33 only
** Mark 331/332 only

Mark 39/39MX Series

Electric Three-Way Control Valves

The Mark 39 is a motor-operated three-way control valve that combines the performance and excellent shutoff characteristics of the Jordan sliding gate seat with the time-proven quality of the Honeywell industrial motor. Available for either diverting (Mark 39) or mixing (Mark 39MX) service, the Mark 39 utilizes two sets of seats to handle higher than usual pressure drops while maintaining ANSI Class IV shutoff.

FEATURES

- Heavy-duty industrial grade motor:
 - Die-cast magnesium housing
 - NEMA 3 (weather protection) rated
 - UL® listed and CSA approved
 - Oil emmersed motor and gear train for long-term, reliable performance
- Sliding Gate Seats — features advanced sliding gate seat technology.
 - Straight-through flow for reduced turbulence and quiet operation
 - Short stroke for fast response and accurate regulation.
 - Easy interchangeable Cv's
 - Tight shutoff due to overlap of seat closure area



SPECIFICATIONS

Sizes: 1-1/2" & 2" (DN40 & DN50)

End Connections

- Threaded
- Flanged

Body Materials

- Carbon Steel
- Stainless Steel

Trim Materials

- 303SS
- 316SS

Seat Materials

- Jorcote on SST - Standard
- Chrome Plated on SST - Optional

Packing: Spring loaded Teflon (to 500°F/260°C); braided (above 500°F/260°C)

Service: Steam, water oil, gas, air, chemicals

Shutoff: ANSI Class IV

Seat Interchangeability: 1-1/2" with 2" (DN40 with DN50)

Power Requirements: 24 VAC, 50/60 Hz (optional transformer required for 120 VAC)

Command Signals: Proportional control (0-135 ohms); on-off control; current command (4-12, 4-20, 12-20 mA DC standard); voltage command 2-10 VDC

Operating Time (approximate): 30 seconds

Ambient Temperature Limit for Motors: -40°F to 150°F (4,4°C to 65,6°C)

Flow Paths

- Mark 39

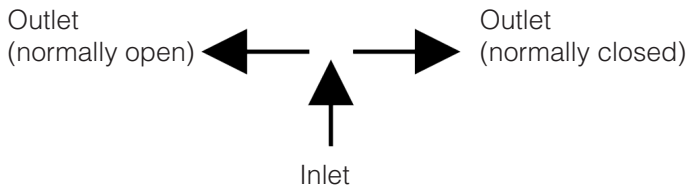

- Mark 39MX

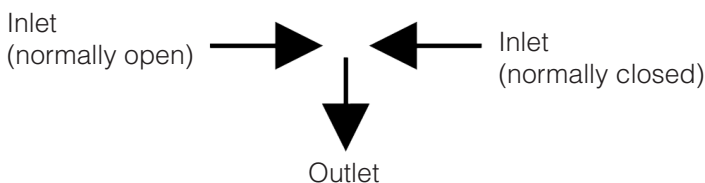

Loading Effect for Electric Control

Control Signal (mA DC)	Net Loading Effect on mA Controller (ohms)*
4 - 12	67
4 - 20	67
12 - 20	67

Caution: Check controller literature to be certain that the controller is compatible with the loading.

Cv (Kv) Ratings and Maximum Allowable ΔP:

Cv (Kv)	Valve Size	Seat Material	Max ΔP, psi (bar)
15 (13)	1-1/2" & 2" (DN40 & 50)	SST	75 (5,2)
25 (22)			
30 (26)		Jorcote	150 (10,3)

*** Low Flow Trim Available:** reduced Cv's (Kv's) can be used in a valve of any size as long as the required flow is a smaller value than the standard Cv (Kv) for the particular size. In addition, the following Cv's (Kv's) can be provided.

1.6 (1,4)	0.84 (0,72)	0.42 (0,36)	0.21 (0,18)
0.08 (0,07)	0.04 (0,03)	0.02 (0,017)	0.008 (0,007)
0.004 (0,003)	0.002 (0,002)	0.0008 (N/A in 316SS) (0,00069)	

Maximum Working Pressure & Temperature

Maximum Pressure @ 100°F (38°C), PSI/°F (Bar/°C)						
Packing	CS Body			SST Body		
	150#	300#	TE	150#	300#	TE
Any	285/100 (20/38)	740/100 (51/38)	1000/100 (69/38)	275/100 (19/38)	720/100 (50/38)	1000/100 (69/38)
Pressure @ Maximum Temperature, PSI/°F (Bar/°C)						
TEF	170/500 (12/260)	600/500 (41/260)	1000/500 (69/260)	170/500 (12/260)	480/500 (33/260)	1000/500 (69/260)
Braided Graphite	125/650 (9/343)	535/650 (37/343)	1000/650 (69/343)	125/650 (8/343)	445/650 (31/343)	1000/650 (69/343)

DIMENSIONS

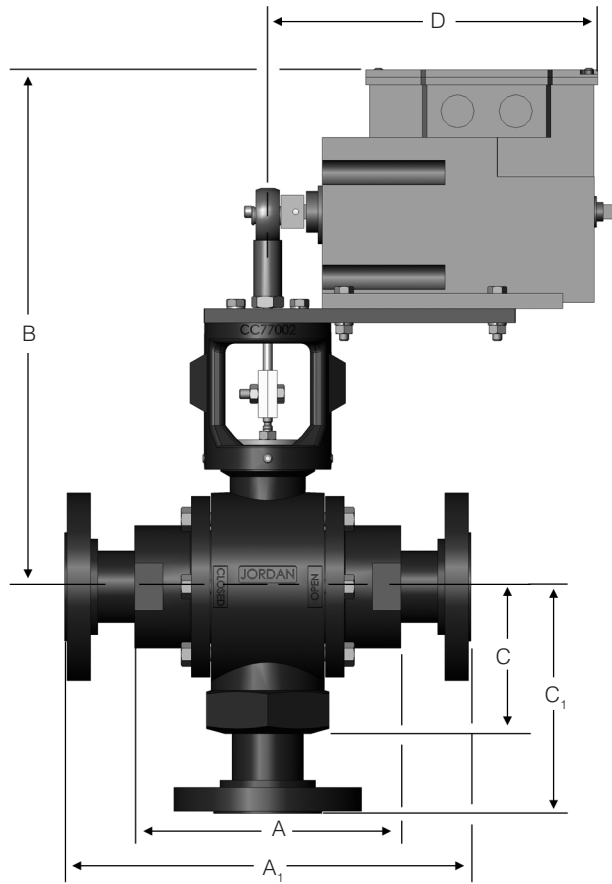

• Threaded Ends

Size	Material	Dimensions (inches)				Weight (lbs)
		A	B	C	D	
1-1/2"	DI/BRZ	7.12	13.70	3.75	7.00	32
	CS/SS	7.12	13.70	3.75	7.00	32
2"	DI/BRZ	7.12	13.70	3.75	7.00	32
	CS/SS	7.12	13.70	3.75	7.00	32

• Flanged Ends

Size	ANSI Flange	Dimensions (inches)				Weight (lbs.)
		A1	B	C	D	
1-1/2"	150#	11.00	13.70	6.00	7.00	38
	300#	11.00	13.70	6.00	7.00	44
2"	150#	11.00	13.70	6.00	7.00	42
	300#	11.00	13.70	6.00	7.00	46

• Threaded Ends, Metric

Size	Flange (PN)	Dimensions (mm)				Weight (kgs)
		A	B	C	D	
40	DI/BRZ	181	348	95	178	15
	CS/SS	181	348	95	178	15
50	DI/BRZ	181	348	95	178	15
	CS/SS	181	348	95	178	15

• Flanged Ends, Metric

Size	Flange (PN)	Dimensions (mm)				Weight (kgs)
		A1	B	C	D	
40	10/16	279	348	152	178	17
	25/40	279	348	152	178	19
50	10/16	279	348	152	178	19
	25/40	279	348	152	178	21

ORDERING SCHEMATIC

Model No	Size	Body Mat'l	1	2	3	4	5	6	7	8	9	10	11	12	14

	Model
39	Diverting
39MX	Mixing

	Size
150	1-1/2" (DN40)
200	2" (DN50)

	Material
CS	Carbon Steel (WCB)
S6	Stainless Steel (CF8M)

1 & 2	End Connections
Pt	NPT
BT	BSPT
BP	BSPP
SW	FSW
F5	150# FE (Except IFE)
F3	300# FE (Except IFE)
ZZ	Non-Standard

3 & 4	Trim
T3	303SS/Teflon Packing
T6	316SS/Teflon Packing
ZZ	Non-Standard

5	Seat Materials
A	303SST
B	316SST
V	303SS/Jorcote
W	316SS/Jorcote

6	Cv (Kv)
9	15 (12,9)
A	25 (21,5)
B	30 (25,8)

7 & 8	Range
RE	Resistance (0 - 135 ohm)
NF	On-Off
42	4-20 mA
41	4-12 mA
12	12-20 mA
ZZ	Non-Standard

9 & 10	Actuator
2L	Standard 2 L.S.
R1	Spring Return 1 L.S.
R2	Spring Return 2 L.S.
ZZ	Non-Standard

11 & 12	Accessories
00	None
TS	Travel Scale
TR	Transformer 120 VAC
SR	Travel Scale & 120V Transformer
FE	Feedback Pot 1-135 ohm
ZZ	Non-Standard

13	PED Compliance
0	Not required
F	CE Category 1



Jordan Valve, a division of Richards Industries
 3170 Wasson Road • Cincinnati, OH 45209
 513.533.5600 • 800.543.7311 • 513.871.0105 (f)
 jordan@richardsind.com • www.jordanvalve.com



Vinnova Exploration
 sales@vinnova.asia
 063-271-9119
 www.vinnova.asia