

Orifice Block Valves

The PG65 block valve is designed for compact side-by-side mounting on orifice flanges and orifice settings, as well as for use with condensate chambers, mercury traps, and seal traps. The slim design enables side-by-side mounting on 2-1/8" centers without staggering the valves with unequal length nipples as required with other valves. This valve provides two outlet ports for use as impulse line connections, pressure gauge mounting or level gauge mounting.

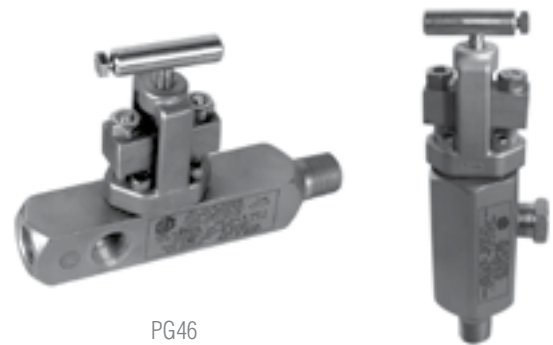

Needle Valves / Bleed Valves

The PN49 is a fully packed needle valve for high pressure and high temperature applications. It is produced in a variety of inlet and outlet sizes.

For critical services, the PB50 and PB59 block and bleed valves feature a fully packed and backseated block valve along with an integral bleed valve. The PB50 features an integral PB24 bleed valve while the PB59 features a fully packed integral bleed valve.



Gauge / Block Valves

Hex Gauge / Block Valves provide three outlet connections to facilitate the mounting of gauges and other static pressure instrumentation in a variety of positions. The design results in a compact installation with minimal leak points.

- The PG46 features the backseated OS&Y bolted bonnet, while the PG48 is supplied with a backseated screwed bonnet.
- The PG47 provides a full port and unrestricted flow, which allows the use of a rod-out tool. Note: there is a pressure limitation of 1500 psi at -20 to 100°F regardless of material.



Features and Benefits

- The Hex Power Valves conform to the Power Standards ANSI B31.1 and B31.3 Specifications
- HEX Valves are 100% Hydro-Tested to the ANSI B31.1 Standard before being shipped.
- HEX bonnets come Standard with Safety Clamp to prevent loosening and are "Back Seated"
- HEX valves have large robust handles and stems for durability and long life

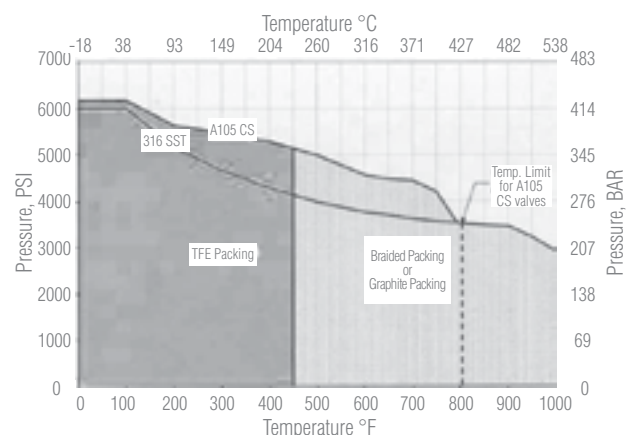

Pressure and Temperature Chart

Temperature, °F (°C)	SA105 Carbon Steel, psig (bar)	SA479 Type 316 Stainless Steel, psig (bar)
-20 to 100 (-28,9 to 37,8)	6170 (425)	6000 (414)
200 (93,3)	5655 (390)	5160 (356)
300 (149)	5450 (376)	4660 (321)
400 (204)	5280 (364)	4280 (295)
500 (260)	5025 (346)	3980 (274)
600 (316)	4730 (326)	3760 (259)
650 (343)	4575 (315)	3680 (254)
700 (371)	4425 (305)	3620 (252)
750 (399)	4230 (292)	3560 (245)
800 (427)	3430 (236)	3520 (243)
850 (454)	—	3480 (240)
900 (482)	—	3460 (238)
950 (510)	—	3220 (222)
1000 (538)	—	3030 (209)

Notes:

1. Pressure / Temperature Ratings with Graphite packing.
2. Maximum temperature for Carbon Steel is 800°F (427°C).
3. PG47 is limited to a maximum pressure of 1500 psig.
4. Please contact factory for additional valve material options.
5. Valves are rated to ANSI B31.1, Class 2500.

How to Order							
Model Number	Seat	Body Material	Inlet Size & Type	Outlet Size & Type	Stem / Tip	Seat Material	Packing
PB59	1 = Integral Hard Seat	P = Carbon Steel (ASTM A105)	31 = 1/2" MNPT	31 = 1/2" FNPT	2 = 316 SS Needle	1 = Integral Hard Seat	3 = Graphite / Grafoil / Graphite
PG46	3 = Integral Hard Seat - "LG" Body	U = Stainless Steel (ASTM A479-316)	32 = 1/2" MSW		4 = 316 SS Non-Rotating	3 = Stellite #6 Insert	
PG47	5 = Integral Hard Seat - "XLG" Body		41 = 3/4" MNPT		5 = 316 SS / Stellite Non-Rotating		
PG48			42 = 3/4" MSW				
PG49							
PB50							
PG65							
PG35	Only Option 1 Available			37 = 1/2" MNPT 47 = 3/4" MNPT*	Only Option 4 Available	Only Option 1 Available	

* Outlet option 37 & 47 only available for PG35

Bolting: ASTM SA193, GR B8M, Type 316, Class 1 and ASTM SA193, GR B7

Bonnet Feature: All screwed bonnets offer standard bonnet safety clamp

Testing: Valves are 100% hydrotested to ANSI B31.1 specifications

Sample Ordering Schematic

PB59	1	U	32	31	4	1	3
------	---	---	----	----	---	---	---

Please consult the HB/HG/HN Series literature for dimensional data.