

The HM54 Series is a double flanged instrument manifold that is used to perform the block, equalizing and vent requirements of differential pressure transmitters. For compact, close-coupled installations, the manifold bolts directly to the instrument and can be mated directly to the orifice flange using futbol flanges and short nipples. For remote installation, tube adaptors are used with the futbol, making the installation similar to the HM53.

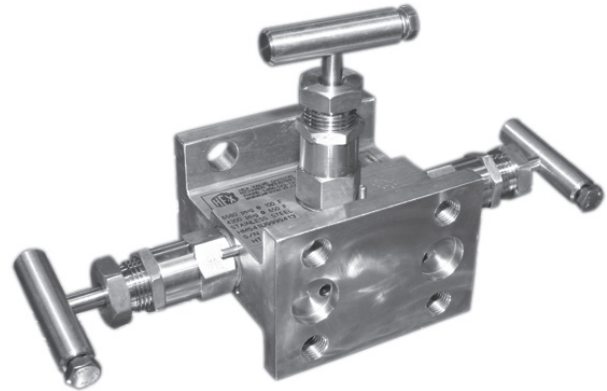

Features and Benefits

- **VOC emissions compliance:** Unique TFE-Chevron and high temperature 1625G/Grafoil/1625G packing designs have been certified to meet and exceed the 100 ppm EPA 1998 Emission Standards
- **Non-rotating tip (NRT) stem:** Provides tight, repeatable shutoff without the galling or cross-scoring that occurs on ball type stems. The NRT conical stem tips stops rotating with it contacts the seat, so further torque turns the stem, but not the tip, preventing damage to the tip
- **New minimum emission flange:** New outlet flange face protrusion mates transmitter inlet cavity, providing a gasket ID barrier that offers maximum protections against gasket cold flow and fugitive emissions
- **New removable bracket option:** Specify our removable bracket option and mount the manifold, not the transmitter
- **Fully backseated bonnets:** Prevent accidental stem removal and blowout. Unique design minimizes emissions while offering easy access to the packing

Flow Schematic

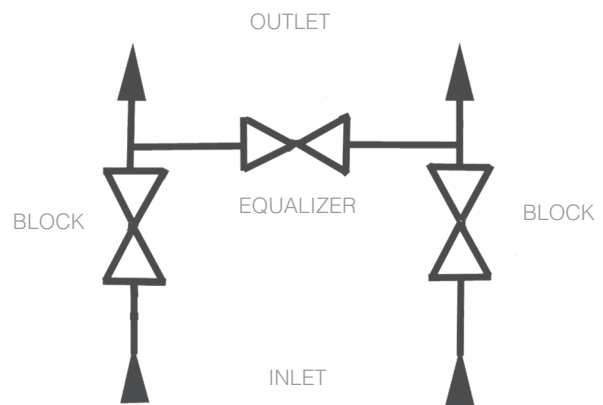

Pressure and Temperature Chart

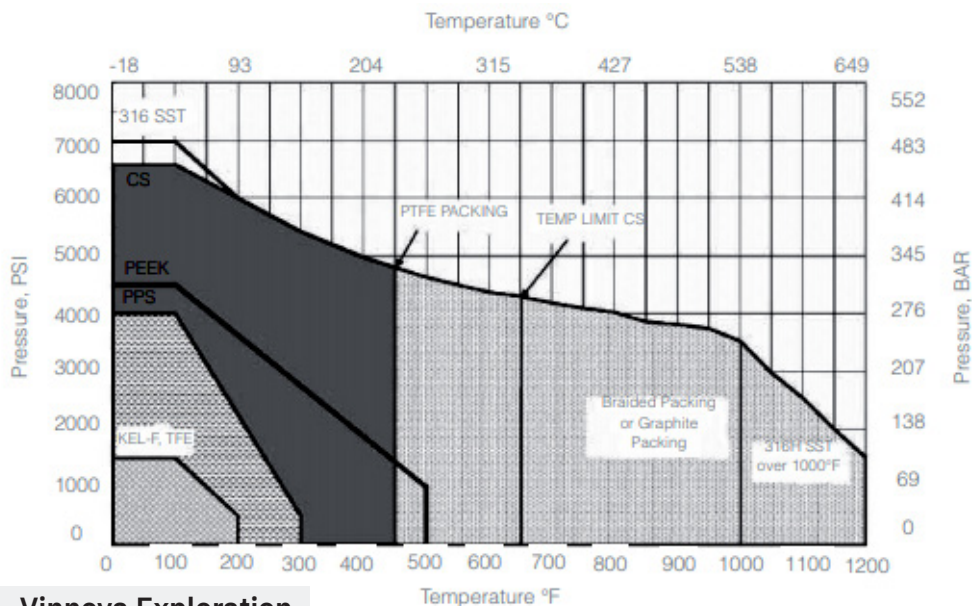

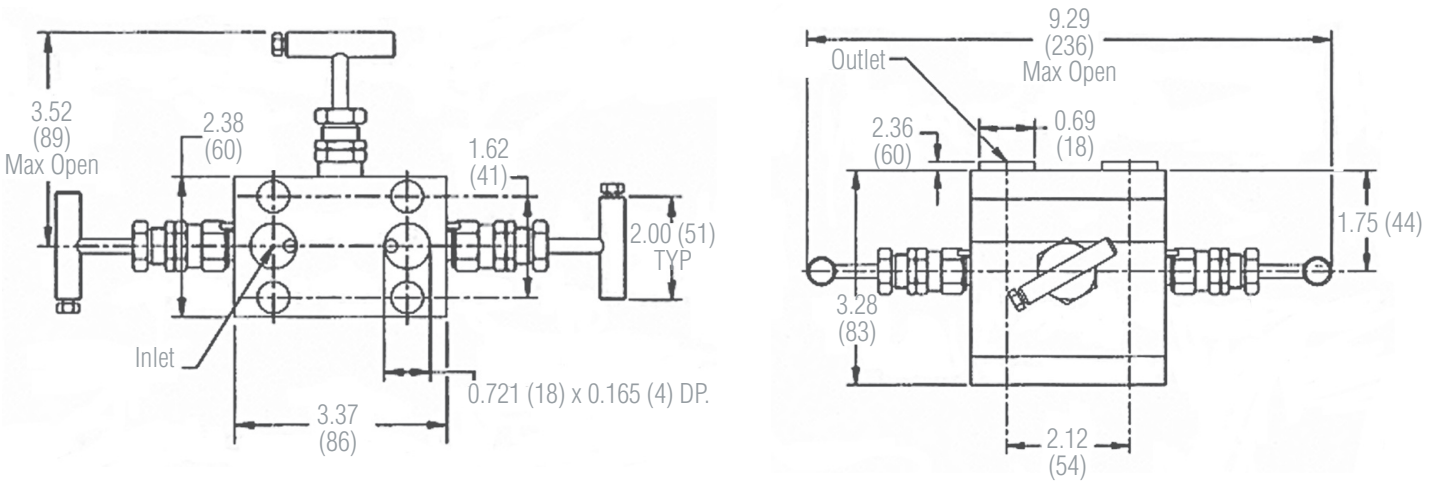
Dimensions

How to Order

Model Number	Seat/ Body Configuration	Body Material	Inlet Size	Inlet Type	Outlet Size	Outlet Type	Stem/Tip	Seat Material	Packing	Options	Options
HM54	1 = Hard (6000 psi)	S = CS	9 = Flanged	9 = Flanged	9 = Flanged	9 = Flanged	2 = 316 SS Needle/ Plug (soft seat only)	1 = Integral (hard)	2 = TFE-Chevron	0 = No Selection	K = 1/8" Test Ports
	2 = Soft (3000 psi)	U = SS					4 = 316/316SS NRT	4 = PPS	3 = Graphite	1 = CS Mtg Bkt Kit	L = 1/8" Purge Ports
								5 = KEL-F		5 = Safety Handle	
								6 = TFE		H = SS Mtg Bkt Kit	
								9 = PEEK		J = SS Mtg Hdwre	

Sample Ordering Schematic

HM54	1	U	9	9	9	9	4	1	2	0	L
------	---	---	---	---	---	---	---	---	---	---	---