

Hex Rigid Mount Manifolds mount directly to the pipe stand securing the impulse lines so the transmitter can be installed or removed independently of the piping. They feature a "standard" two or three valve manifold or a blowdown manifold with an integral, welded mounting plate. The secure, welded design allows for fast and easy installation of gauge and differential pressure transmitters on vertical or horizontal pipe stands. Choose from five models to meet your instrumentation requirements.

HM10: Single flange static pressure manifold for gauge pressure instrumentation

HM13: Single flanged three valve manifold for differential pressure transmitters

HM14: Double flanged three valve manifold for differential pressure transmitters

HM16: Single flanged manifold featuring independent blowdown valves

HM18: Single flanged two valve manifold for use with level instrumentation

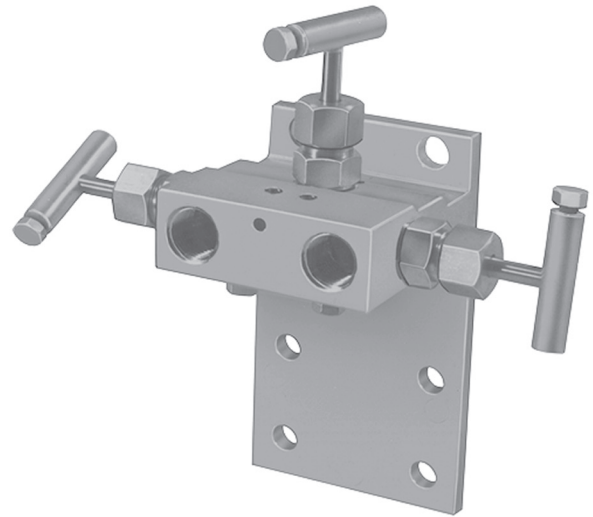

HM13 Single Flanged Three Valve Manifold

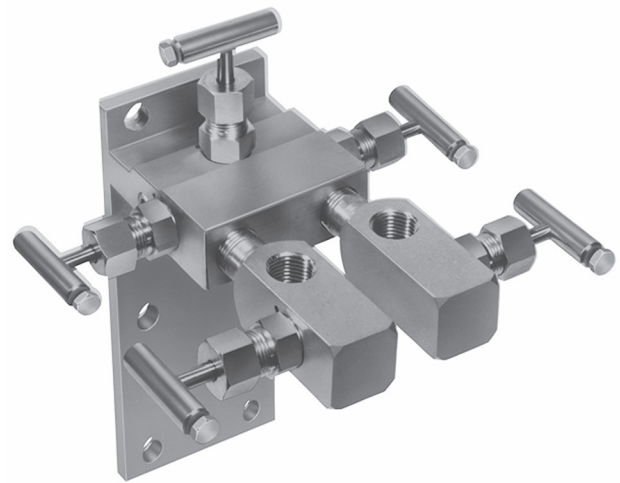

HM16 Single Flanged Blowdown Manifold

Features and Benefits

- **Non-rotating tip (NRT) stem:** Provides tight, repeatable shutoff without the galling or cross-scoring that occurs on ball type stems. Because the NRT conical stem tip stops rotating when it contacts the seat, further torque turns the stem, but not the tip, protecting the stem tip from damage
- **Your choice of mounting options:** Choose from single flanged or double flanged designs, and three or five valve assemblies to match your application needs and to mate with your specific transmitter
- **Fully packed bonnets:** Four rings of Teflon-Chevron packing

Pressure and Temperature Chart

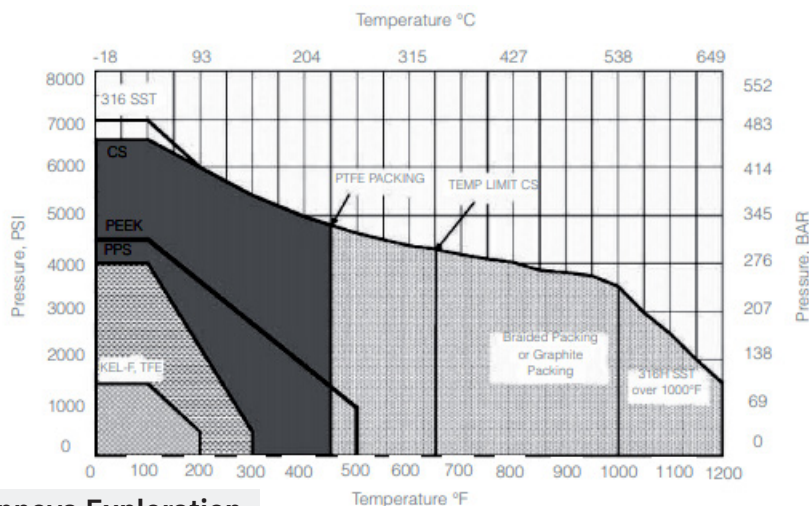

Dimensions - HM10 Series

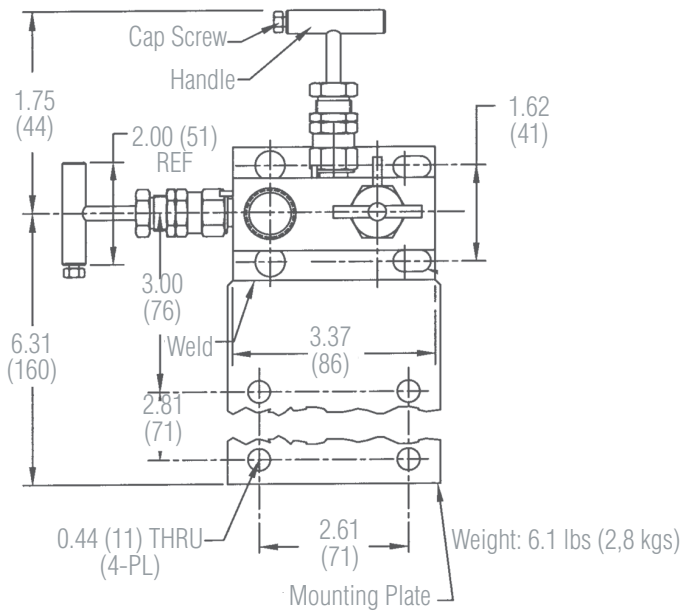
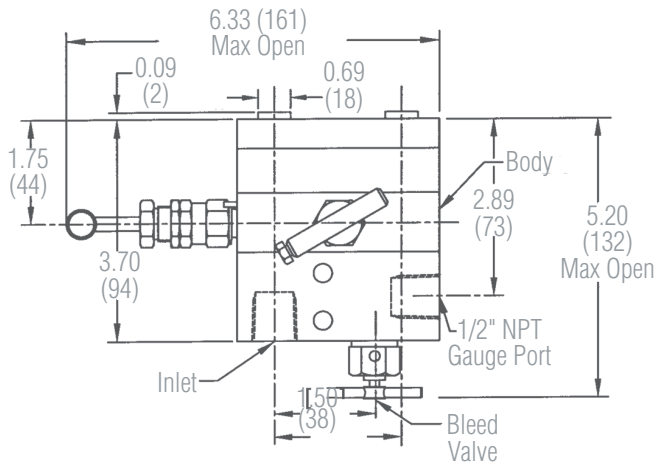

Dimensions - HM13 Series

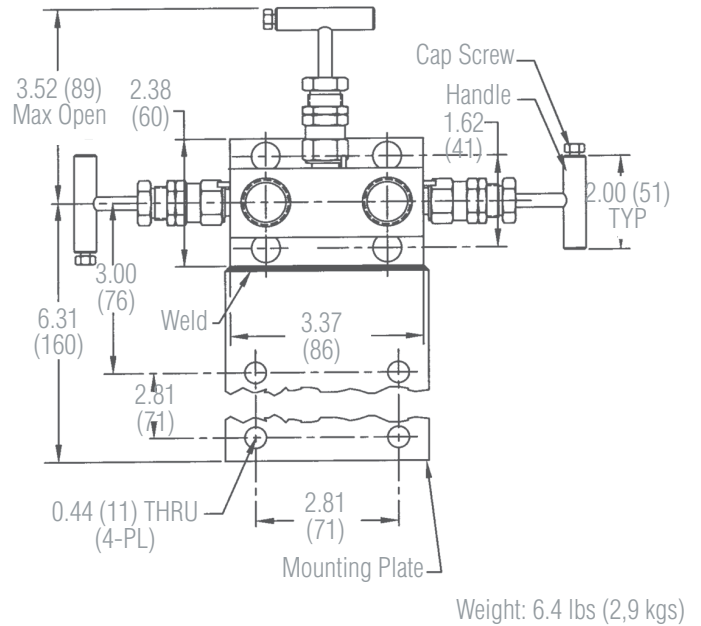
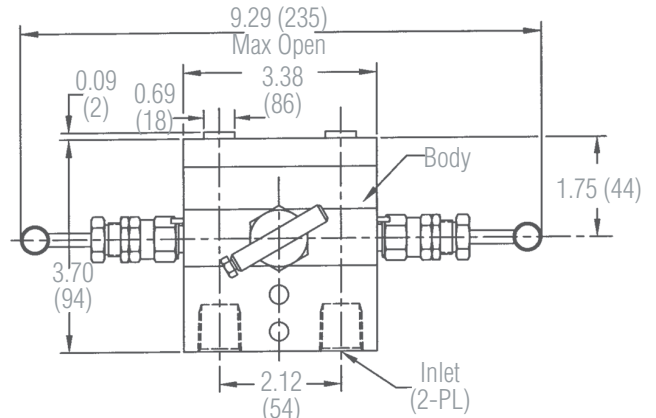

Dimensions - HM14 Series

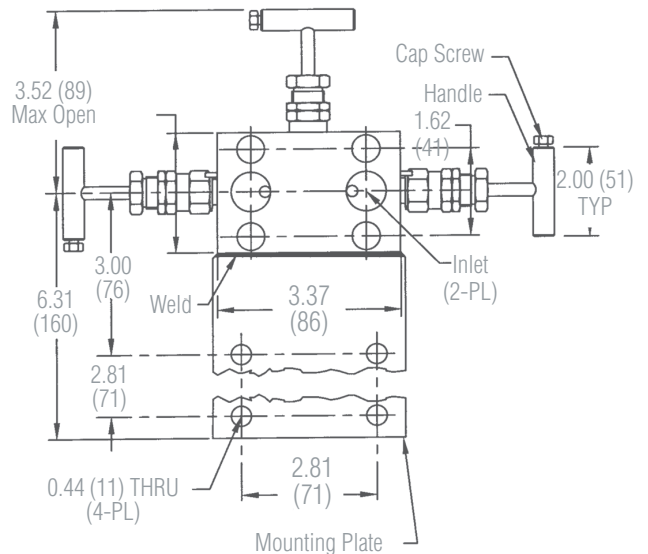
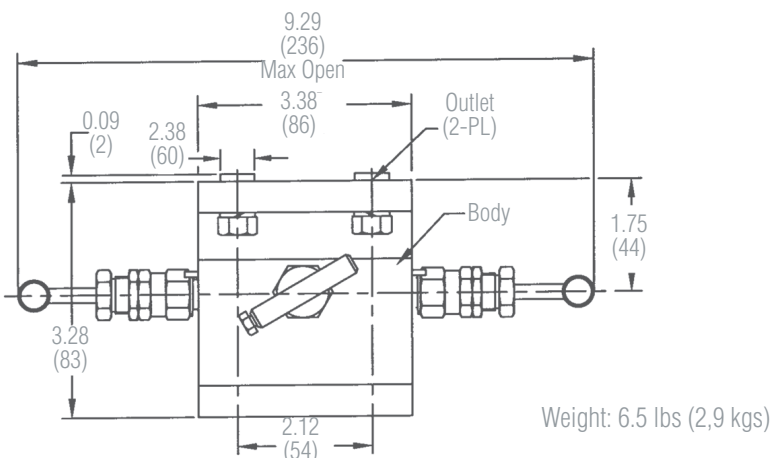

Dimensions - HM16 Series

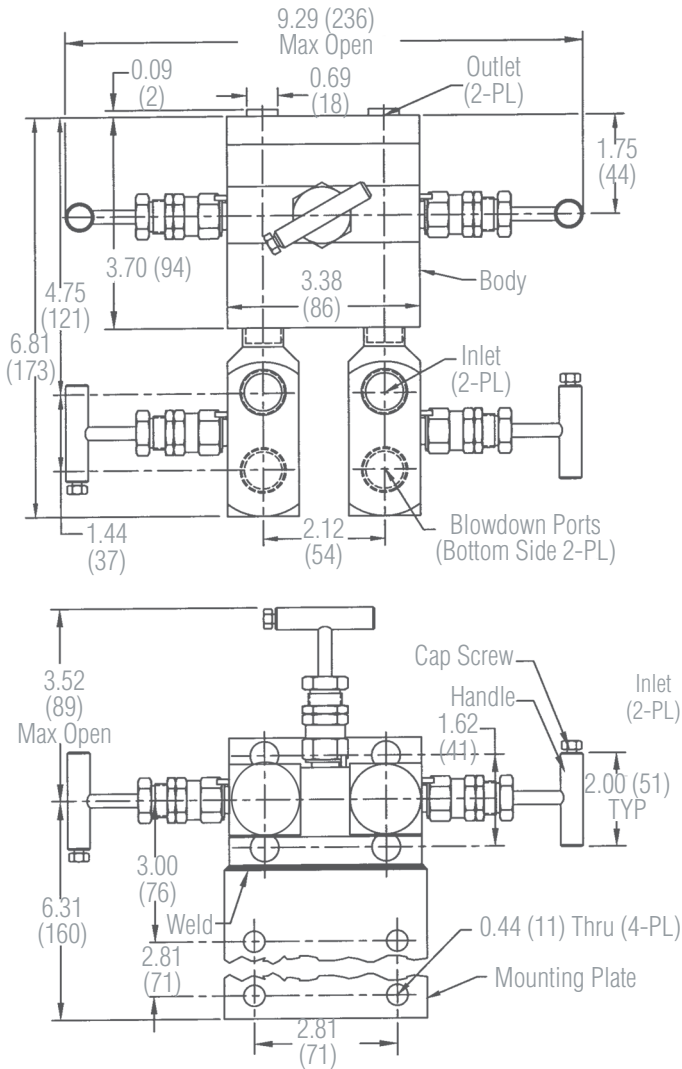

Weight: 9.0 lbs (4,1 kgs)

Dimensions - HM18 Series

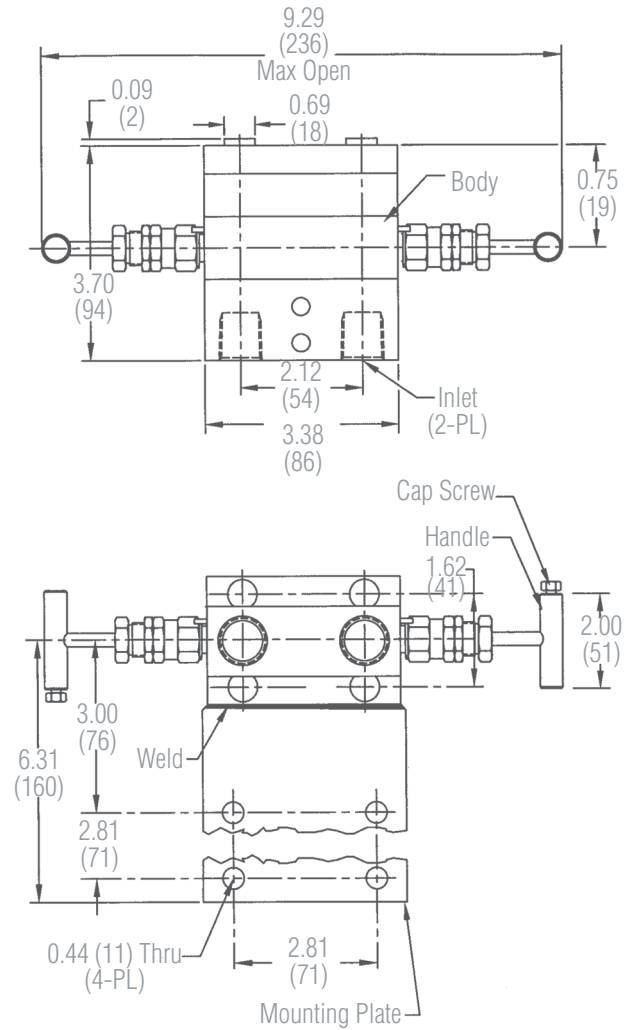

Weight: 6.2 lbs (2,8 kgs)

Notes:

- Orifice size: 0.19"
- Bonnet position will vary from hard seated valves to soft seated valves. If bonnet location is critical to your application, consult factory for precise location on your specific valve model.
- Hex Valve reserves the right to make specification changes without notice

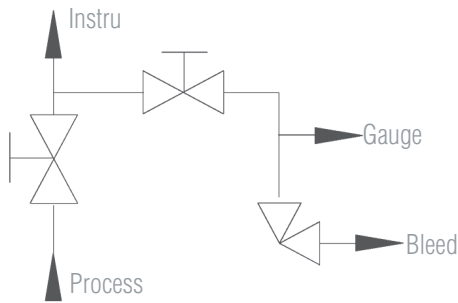
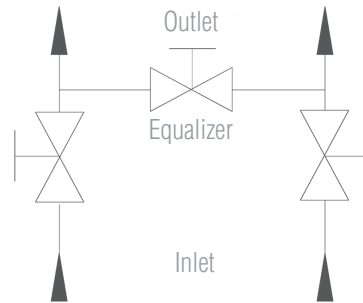
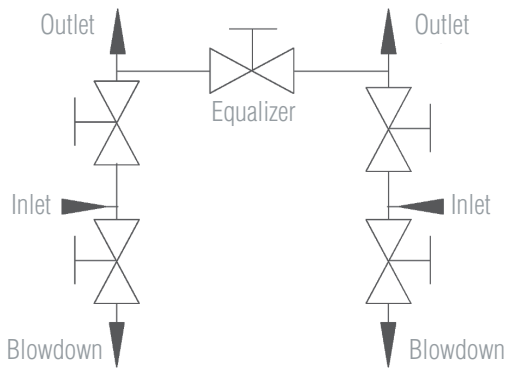
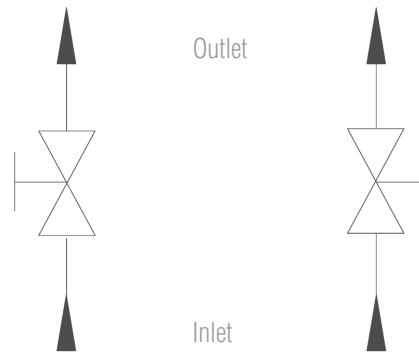
Flow Schematics - HM10

Flow Schematics - HM13 & 14

Flow Schematics - HM16

Flow Schematics - HM18

How to Order

Model Number	Seat/ Body Configuration	Body Material	Inlet Size	Inlet Type	Outlet Size	Outlet Type	Stem/Tip	Seat Material	Packing	Options	Options
HM10	1 = Hard (6000 psi)	S = CS	3 = 1/2"	3 = FNPT	9 = Flanged	9 = Flanged	2 = 316 SS Needle/ Plug (soft seat only)	1 = Integral (hard)	2 = TFE	N = Steam Trace Block	K = 1/8" Test Ports
HM13	2 = Soft (3000 psi)	U = SS	A = 1/2" Single Ferrule Integral Tube Nut or Fitting	A = Tube Nut			4 = 316/316SS NRT	4 = PPS	3 = Graphite	U = Grafoil Flange Gasket	L = 1/8" Purge Ports
HM14			B = 1/2" Double Ferrule Integral Tube Nut or Fitting	B = Tube Fitting/Flange				5 = KEL-F			
HM16			C = Swagelok™ Tube Fitting/ Flange	9 = Flanged (HM14)				6 = TFE			
HM18			9 = Flanged (HM14)					9 = PEEK			

Sample Ordering Schematic

HM10	1	U	3	3	9	9	4	1	2	N	L
------	---	---	---	---	---	---	---	---	---	---	---