

The HB24/25/26/27 Series Bleed Valves are available individually, or optionally threaded into an unused outlet port on a variety of Hex Valve models. Used for bleeding off high pressure media, the HB24 & HB25 incorporate backout stops to prevent inadvertent removal of the stem; the HB26 does not include this feature to allow for stem removal to facilitate calibration through the valve.

- HB24: features an easy to use “T” handle plus directional discharge/drain/tube.
- HB25: incorporates a “hex” head screw to reduce tampering, and also supplies a directional discharge tube.
- HB26: features a “hex” head screw, but no discharge/drain tube.
- HB27: Incorporates a “Mini-Bonnet” (packed) assembly with discharge/drain tube



### Features and Benefits

**Reduce Costs and Installation Time:** Conventional instrument piping requires a costly arrangement of valves, nipples, and fittings that can be streamlined into a single valve assembly. Hex block & bleed valves minimize threaded connections while combining multiple valve functions. You will achieve tight shutoff and bleed capabilities in one compact assembly while reducing installation time, labor costs, and space requirements while lowering overall piping costs.

### Dimensions – HB24 and HB25 – Inches

Inlet Size	A	B	C	D
1/8"	0.62	0.69	0.82	1.85
1/4"	0.62	0.82	0.82	1.85
3/8"	0.75	0.82	0.87	1.85
1/2"	0.87	1.00	0.86	2.14
3/4"	1.12	1.00	0.98	2.14
1"	1.37	1.32	1.09	2.54

### Dimensions – HB24 and HB25 – Metric

Inlet Size	A	B	C	D
DN6	15,7	17,5	20,8	47,0
DN8	15,7	20,8	20,8	47,0
DN10	19,1	20,8	22,1	47,0
DN15	22,1	25,4	21,8	54,4
DN20	28,4	25,4	24,9	54,4
DN25	34,8	33,5	27,7	64,5

### Dimensions – HB24 Series

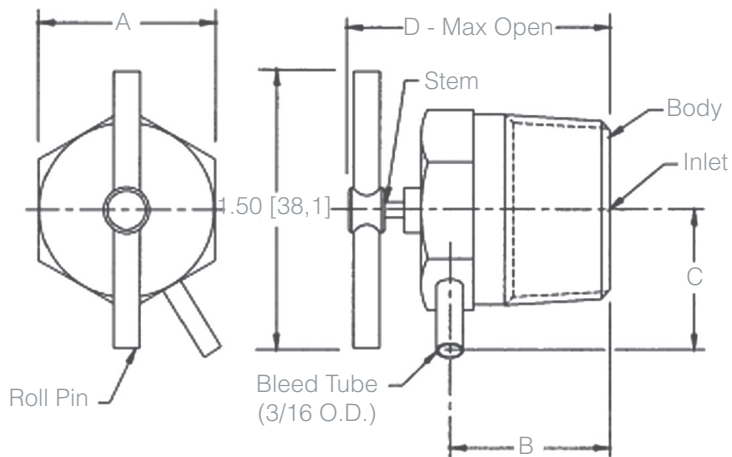

### Dimensions – HB25 Series

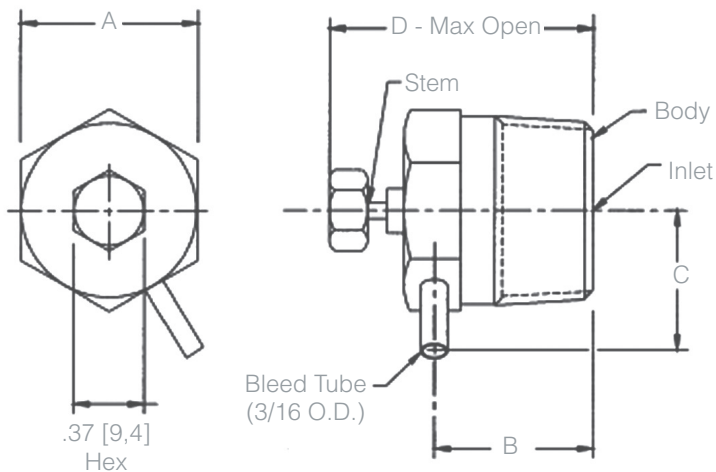

### Dimensions – HB26 Series

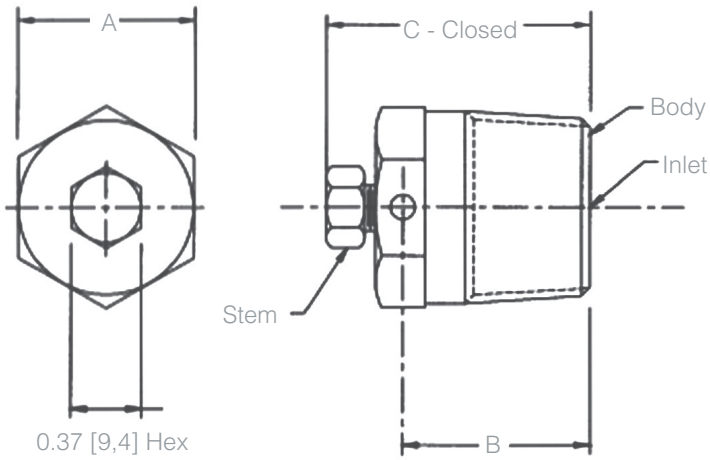

**Dimensions – HB26 – Inches**

Inlet Size	A	B	C
1/8"	0.62	0.69	1.29
1/4"	0.62	0.82	1.29
3/8"	0.75	0.82	1.29
1/2"	0.87	1.00	1.36

**Dimensions – HB26 – Metric**

Inlet Size	A	B	C
DN6	15,7	17,5	32,8
DN8	15,7	20,8	32,8
DN10	19,1	20,8	32,8
DN15	22,1	25,4	34,5

### Dimensions – HB27 Series

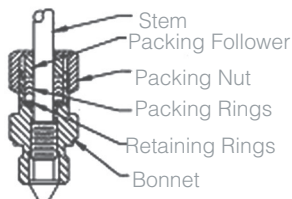
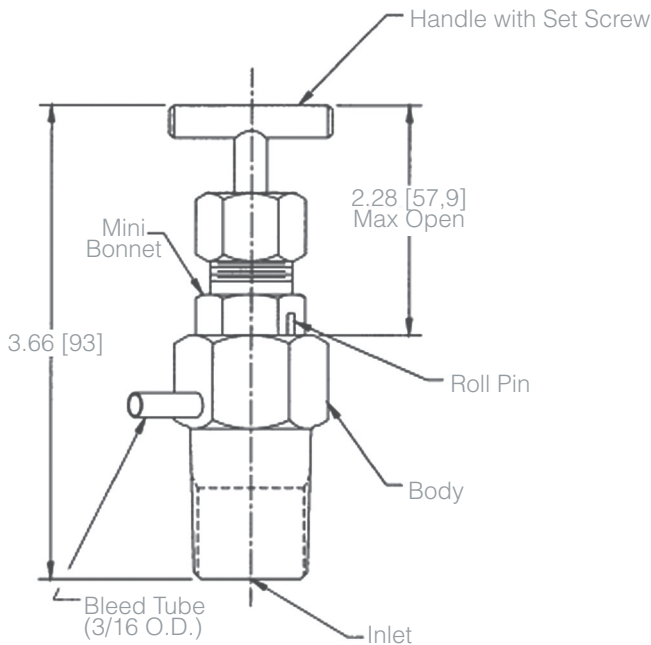

Bonnet Detail

### Flow Schematics for HB24/25/26/27

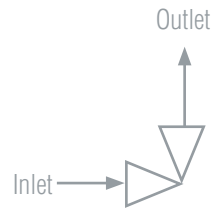

- Orifice: 0.127" bleed
- Maximum weight: 0.25 pounds (0,11 kgs)

### Pressure and Temperature Chart

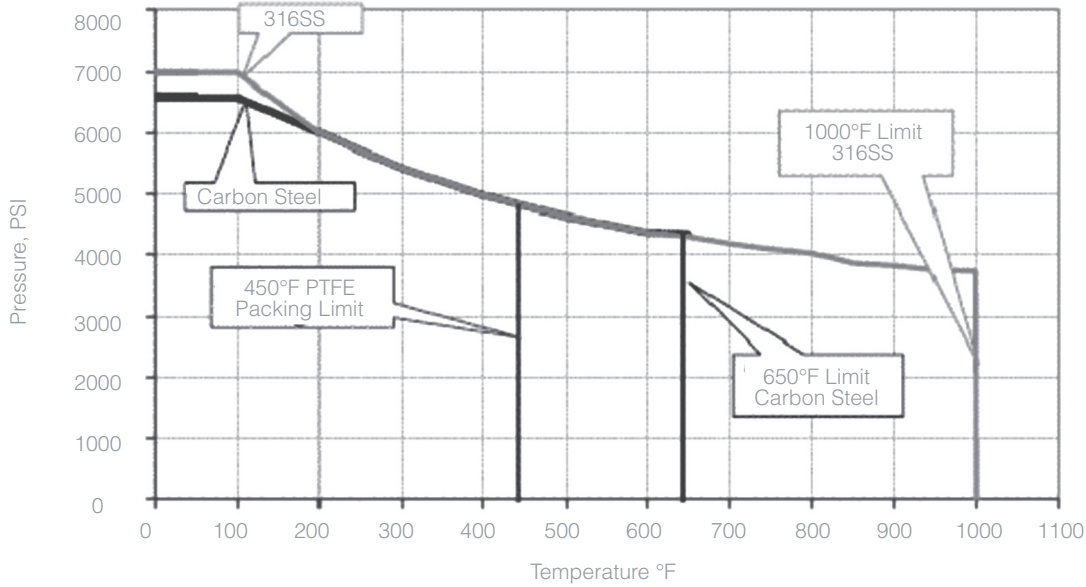

How to Order						
Model Number	Seat Configuration	Body Material	Inlet Size	Inlet Type	Stem Material	Packing*
HB24/25/26/27	1 = Hard	S = Carbon Steel (A108)	1 = 1/4"	1 = MNPT	2 = 316 SS	2 = Teflon
		U = Stainless Steel (SA-479; 316)	2 = 3/8"	2 = MSW	3 = 316SS NACE	3 = Graphite
		P = Carbon Steel (A105)	3 = 1/2"			
		D = 316 / NACE	4 = 3/4"			

\* HB27 only

### Sample Ordering Schematics

HB24	1	S	2	1	2	
HB27	1	S	3	1	2	2