

Features

- ISO / DIN valve interface
- Mounting in any position
- Thermal overload protection (AC & DC except 12 VDC)
- Friction brake (standard for AC motors except 24 VAC)
- Permanent lubrication
- Reversing permanent split capacitor motors
- Manual override handwheel standard most sizes / housing
- Many options including: auxiliary limit switches, 4-20 mA positioner, power off brake, heater, heater & thermostat, light indicator, feedback potentiometer, speed control, timer, two-wire control relay

ER- Series

Quick Spec	
Product Scope	
Size Range	ER1, 2, 3, 4, 6, 10, 15, 20, 38, 50, 70, 120, 140
Maximum Operating Torque	ER1: up to 100 in-lbs ER140: up to 14040 in-lbs
Cycle Time	2.5 - 58 sec. (varies with size, voltage, duty cycle, installed accessories)
Motor Voltage	24, 115, 230 VAC; 24 VDC
Duty Cycle	ER1 - ER15: 25% ER20 - ER140: 100%
Enclosures	NEMA 4, 4X, 7
Temperature	-40°F to +150°F (-40°C to +65°C)
Limit Switches (Open-Close & Aux.)	(125/250 VAC) 15A, 0.5 HP; (125VDC) 0.1A
Terminal Strip Connection	8 pt. AWG14
Materials	(Housing) Die Cast Aluminum
	(Gears) Heavy Duty Hardened Steel
	(Hardware) 300 Series SS
Finish	Thermally Bonded Polyester Coating
Design Standards*	
CSA	File No. LR 79567 (See Eng. data for applicability)
Mounting Flange (Valve)	ISO 5211

* Varies with size, enclosure, voltage, installed accessories; see Engineering data for detailed specifications

Output Torque					
Description	Size				
	ER1	ER2	ER3	ER4	ER6
Output Torque, in-lb	100	200	300	400	675
Standard Motor Volt/Hz/Ph./Duty Cycle	115 VAC / 60 Hz / 1 Ph. / 25%				
Cycle Time, sec/90° FL/LR Current, amp	2.5 sec 0.4 / 0.55 amp	5 sec 0.38 / 0.75 amp	5 sec 0.38 / 0.75 amp	10 sec 0.38 / 0.75 amp	15 sec 0.38 / 0.75 amp
Optional Ext'd Duty Motor Volt/Hz/Ph./Duty Cycle	115 VAC / 60 Hz / 1 Ph. / 75%				
Cycle Time, sec/90° FL/LR Current, amp	---	10 sec 0.38 / 0.75 amp	10 sec 0.38 / 0.75 amp	20 sec 0.38 / 0.75 amp	30 sec 0.38 / 0.75 amp
Optional Motor Volt/Hz/Ph./Duty Cycle	230 VAC / 60 Hz / 1 Ph. / 25%				
Cycle Time, sec/90° FL/LR Current, amp	2.5 sec 0.32 / 0.68 amp	5 sec 0.18 / 0.38 amp	5 sec 0.18 / 0.38 amp	10 sec 0.18 / 0.38 amp	15 sec 0.18 / 0.38 amp
Optional Motor Volt/Hz/Ph./Duty Cycle	24 VAC / *Hz / 1 Ph. / 75%				
Cycle Time, sec/90° FL/LR Current, amp	3 sec 0.4 / 2.4 amp	5 sec 0.7 / 3.2 amp	5 sec 0.7 / 3.2 amp	10 sec 0.7 / 3.2 amp	15 sec 0.9 / 3.2 amp
Optional Motor Volt/Duty	12 VDC / 75%				
Cycle Time, sec/90° FL/LR Current, amp	3 sec 0.6 / 2.9 amp	5 sec 1.3 / 4.2 amp	5 sec 1.3 / 4.2 amp	10 sec 1.3 / 4.2 amp	15 sec 1.7 / 4.2 amp
Optional Motor Volt/Duty	24 VDC / 75%				
Cycle Time, sec/90° FL/LR Current, amp	3 sec 0.2 / 2.4 amp	5 sec 3.2 amp	5 sec 0.7 / 3.2 amp	10 sec 0.7 / 3.2 amp	15 sec 0.9 / 3.2 amp
Available NEMA Enclosures	4 (Fig. 1) 4-7-9 (Fig. 2)	4, 4X Reg. Hsg (Fig. 3); 4, 4X Deep Base Hsg. (Fig. 4)**, 7, 4/7, 4X/7 Hsg. (Fig. 5)		4, 4X, 6 (Fig. 6); 7, 4/7, 4X/7 (Fig. 7)	
Certification	NEMA 4 115 VAC std. duty cycle, CSA certified	NEMA 7, C, US certified by CSA		NEMA 4 115 & 230 VAC std. duty cycle, CSA & C, US certified NEMA 7 C, US certified by CSA	
Manual Override	Non-declutch std. on NEMA 4 115 & 230 Vac. NA on other NEMA 4 & all NEMA 7 voltage	Non-declutch std.; Declutch w/hwl opt. 12 VAC and all DC voltage must be declutch. NA Deep Base Hsg.		Declutch w/hwl. std.	
Visual Position Indication	Dome std.	Dome std.		Dome std.	
Spring Friction Brake	Standard for AC motors except 24 VAC				
Power Off Motor Brake	Not available	Optional			
Heater Option	Heater & thermostat required 0°F (-18°C) and below				
Mounting Dim., in.	F03 / F05	F05		F07	
Output Shaft, in.	0.354 (9mm) Female Star	0.551 (14mm) Female Star		0.669 (17mm) Female Star	
Weight, lb	5	NEMA 4 Reg. — 6 NEMA 4 Deep Base — 7 NEMA 4/7 — 15		NEMA 4/4X — 13 NEMA 7 — 16	

* 24 VDC rectified

** Deep base housing required on NEMA 4 ER2 and ER3 for 3 and 4 aux. limit switches, 4-20 mA card, speed control and timer

Output Torque				
Description	Size			
	ER10	ER15	ER20	ER38
Output Torque, in-lb	1000	1500	2000	3840
Standard Motor Volt/Hz/Ph./Duty Cycle	115 VAC / 60 Hz / 1 Ph. / 25%		115 VAC / 60 Hz / 1 Ph. / 100%	
Cycle Time, sec/90° FL/LR Current, amp	15 sec 3.8 / 0.75 amp	30 sec 3.8 / 0.75 amp	12 sec 1.6 / 2.9 amp	14 sec 1.6 / 2.9 amp
Optional Ext'd Duty Motor Volt/Hz/Ph./Duty Cycle	115 VAC / 60 Hz / 1 Ph. / 75%		—	
Cycle Time, sec/90° FL/LR Current, amp	30 sec 0.38 / 0.75 amp	60 sec 0.38 / 0.75 amp	—	
Optional Motor Volt/Hz/Ph./Duty Cycle	230 VAC / 60 Hz / 1 Ph. / 25%		230 VAC / 60 Hz / 1 Ph. / 100%	
Cycle Time, sec/90° FL/LR Current, amp	15 sec 0.38 / 0.75 amp	30 sec 0.38 / 0.75 amp	12 sec 1.03 / 2 amp	14 sec 1.03 / 2 amp
Optional Motor Volt/Hz/Ph./Duty Cycle	24 VAC / *Hz / 1 Ph. / 75%			
Cycle Time, sec/90° FL/LR Current, amp	15 sec 1.1 / 3.2 amp	30 sec 1.1 / 3.2 amp	12 sec 3.7 / 25 amp	14 sec 3.7 / 25 amp
Optional Motor Volt/Duty Cycle	12 VDC / 75%			
Cycle Time, sec/90° FL/LR Current, amp	15 sec 2.2 / 4.2 amp	30 sec 2.2 / 4.2 amp	12 sec 6.9 / 4.8 amp	14 sec 6.9 / 4.8 amp
Optional Motor Volt/Hz/Ph./Duty Cycle	24 VDC / 75%			
Cycle Time, sec/90° FL/LR Current, amp	15 sec 1.1 / 3.2 amp	30 sec 2.2 / 4.2 amp	12 sec 3.7 / 25 amp	14 sec 3.7 / 25 amp
Available NEMA Enclosures	4, 4X, 6 (Fig. 6); 7, 4/7, 4X/7 (Fig. 7)		4, 4X (Fig. 8); 7, 4/7, 4/4X (Fig. 8)	
Certification	NEMA 4 115 & 230 VAC std. duty cycle, CSA & C, US certified NEMA 7 C, US certified by CSA		NEMA 4 & 7, C, US certified by CSA (CSA certified up to 2000 in-lb)	
Manual Override	Declutch w/hwl. std.			
Visual Position Indication	Dome std.			
Spring Friction Brake	Standard for AC motors except 24 VAC			
Power Off Motor Brake	Optional			
Heater Option	Heater & thermostat required 0°F (-18°C) and below			
Mounting Dim., in.	F07		F07	
Output Shaft, in.	0.669 (17mm) Female Star		Male, 1.125D x 1.19 Long with (2) Flats 0.874 Across x 0.88 Long	
Weight, lb	NEMA 4/4X — 13 NEMA 7 — 17	NEMA 4/4X — 17 NEMA 7 — 17	30	

Output Torque				
Description	Size			
	ER50	ER70	ER120	ER140
Output Torque, in-lb	5000	7020	11500	14040
Standard Motor Volt/Hz/Ph./Duty Cycle	115 VAC / 60 Hz / 1 Ph. / 100%			
Cycle Time, sec/90° FL/LR Current, amp	38 sec 1.6 / 2.9 amp	38 sec 1.6 / 2.9 amp	58 sec 2.8 / 7.1 amp	58 sec 2.8 / 7.1 amp
Optional Ext'd Duty Motor Volt/Hz/Ph./Duty Cycle	230 VAC / 60 Hz / 1 Ph. / 100%			
Cycle Time, sec/90° FL/LR Current, amp	38 sec 1.03 / 2 amp		58 sec 1.03 / 2 amp	58 sec 1.03 / 2 amp
Optional Motor Volt/Hz/Ph./Duty Cycle	230 VAC / 60 Hz / 3 Ph. / 100%			
Cycle Time, sec/90° FL/LR Current, amp	38 sec 1.26 / 4.3 amp		58 sec 1.26 / 4.3 amp	58 sec 1.26 / 4.3 amp
Optional Motor Volt/Hz/Ph./Duty Cycle	24 VAC / *Hz / 1 Ph. / 75%			
Cycle Time, sec/90° FL/LR Current, amp	38 sec 5 / 25 amp		58 sec 3.7 / 2.5 amp	58 sec 14 / -- amp
Optional Motor Volt/Duty	12 VDC / 75%			
Cycle Time, sec/90° FL/LR Current, amp	38 sec 10 / 48 amp		58 sec 6.9 / 48 amp	---
Optional Motor Volt/Duty	24 VDC / 75%			
Cycle Time, sec/90° FL/LR Current, amp	38 sec 5 / 25 amp		58 sec 3.7 / 2.5 amp	58 sec 14 / -- amp
Available NEMA Enclosures	4, 4X, 7 (Fig. 9); 7, 4/7, 4/4X (Fig. 9)			
Certification	Not Available			
Manual Override	Declutch w/hwl. std.			
Visual Position Indication	Dome std.			
Spring Friction Brake	Not available (gears are self locking)			
Power Off Motor Brake	Optional			
Heater Option	Heater & thermostat required 0°F (-18°C) and below			
Mounting Dim., in.	F14			
Output Shaft, in.	ER50: Male, 1.125 D x 1.19 Long w/ (2) flats 0.874 across x 1.19 long ER70 to ER140: Male 2.38 D x 1.60 Long / (2) flats 1.42 across x 1.50 long			
Weight, lb	100			

* 24 VDC rectified

Technical Specifications	
Description	Specification
Thermal Overload Protection	115 & 230 VAC: Standard (Automatic Thermal Reset) 24 VDC & 24 VAC: Standard (Manual Power-Off Reset) 12 VDC: Not Available
Enclosure Material	Cast Aluminum with 300 Series SS Captured Bolts
Lubrication	Permanent
Installation Position	Universal
Temperature	-40°F to +150° F (-40°C to +65°C)
Terminal Strip Connection	AWG 14
Limit Switches (Open - Close & Auxillary)	15A, 1/2 HP, 125 / 250 VAC 0.1A, 125 VDC

Housing Specification

NEMA Type 4

"Water-tight and dust-tight" NEMA 4 is intended for indoor or outdoor use. NEMA 4 protects enclosed equipment from splashing water, seeping water, falling or hose direct water, and several external condensation. They are sleet proof. NEMA 4 is approximately equivalent to IP56-1.0mm maximum access / dust-tight / protected against power jetting water.

NEMA Type 4X

"Water and dust-tight" with same provisions as Type 4, but also corrosion resistant.

NEMA 7

"Explosion-proof" NEMA 7 is intended for indoor hazardous locations. ER NEMA 7 actuators are designed to meet the requirements for Class I, Groups C and D gases in Division 1 and 2 areas; and Class II, Groups E, F, and G dusts in Division 1 and 2 areas. Division 1 means an explosive concentration of the hazardous material may be continuously, intermittently, or periodically present under normal operating conditions. Division 2 means an explosive concentration of the hazardous material is present only under fault conditions, and if such a condition occurs, it will only exist for a short period. NEMA 7 is approximately equivalent to CENELEC EEx d IIA or IIBT5.

Duty Cycle

The duty cycle is the ratio of actuator on time to on plus off time, and is used to determine the proper actuator motor so that the thermal overload in the motor is not exceeded. If the thermal overload does shut down the motor, the motor must be allowed to cool for a short period of time so that the thermal overload resets. Extended (75% or 100%) duty motors are always used with actuators with positioner cards, because the actuator may cycle frequently to maintain control.

Mathematically, Duty Cycle = [(On Time) / (On Time + Off Time)] x 100.

Actuator Selection

When sizing actuators, determine the maximum valve torque from the valve torque chart for the seat materials used. This is normally the breakaway torque after the valve has been stationary for the longest period of time. Apply an appropriate service factor to the valve torque to determine the required actuator torque: 20% for normal operation, 50% for dry, dirty or infrequent operation, and 100% for emergency shutoff or throttling control valves.

Available Options

Note: Option code for ordering schematic in parenthesis

- For ER2 through ER15, the 120 VAC motor duty cycle is indicated by the closing time in the schematic: ER2-5-4-115 for normal (25%) duty cycle; ER2-10-4-115 for extended (75%) duty cycle.
- Auxiliary limit switches in addition to the two standard open and closed switches (S, 2S, 3S, 4S) (2) max. on ER1 to ER4, (4 max) on other sizes)
- Motor Brake, power-off (B)
- Handwheel (HW) (See technical specs for standard, option or not available) and rotating or declutchable
- Heater, Condensation Control (H)
- Heater & Thermostat, Temperature Control (HT) (Heater required at 0°F and below)
- Light Indicator (L)
- Feedback Potentiometer (P) (1 Kohm single turn standard; consult factory for others)
- Speed Control (SC) (ER1 requires separate enclosure; ER2 and ER3 NEMA 4 require the deep base housing)
- Two Wire Control Relay (TW)
- 4-20 mA Positioner (VP) (Includes extended duty motor, and 1 Kohm feedback pot)

Note 1: For ER2 thru ER15 units with 115 VAC motors, the optional 115 VAC extended (75%) duty motor doubles the closing time over the standard (25%) duty motor. Refer to Technical Specifications on pages 3 - 5, and "How to Order ER Series" table on page 7.

Note 2: For units available with both standard and extended duty motors, the extended duty motor is mandatory when supplied with positioner card option.

Note 3: The ER1 with positioner normally uses the ER2 regular housing (Fig. 2 or 4) with an F03 bolt pattern and a 14mm (F05) stem hole. If a 9mm (F03) stem hole is required, the ER1 housing is used with a separate attached enclosure for the positioner.

Note 4: The ER2 and ER3 NEMA 4 with positioner require the deep base housing.

Fail Safe Spring Return Electric Actuators

Consult factory for fail-safe spring return models:

- ES-200: 200 in-lb, light duty, non declutching, VAC only, on-off duty
- AS-400 to AS-1000, 400 to 1000 in-lb, medium duty (approximately 25 cycles a day), non-declutching, VAC only, on-off only
- ASC-400 to ASC-1200, 400 to 1200 in-lb, heavy duty, declutching, VAC and VDC, on-off or modulating

Normal operation by electrical power in both directions, emergency operation by spring to fail position on loss of power.

How to Order									
Actuator Series	Size In-Lb		Closing Time (Nominal ¹)			NEMA		Motor ¹	
			Sec ²	Duty ³	Voltages				
ER	1	100	2.5	25% ⁵	115 VAC, 230 VAC	4	NEMA 4	115	115 VAC (standard)
			3	75%	24 VAC, 12 VDC, 24 VDC				
	2 3	200 300	5	25%	115 VAC, 230 VAC	4X	NEMA 4/4X	230	230 VAC
			10	75%	115 VAC				
	4	400	5	75%	12 VDC, 24 VAC, 24 VDC	7	NEMA 7	230-3	230/460 VAC/3Ph (ER50 to 270 only)
			10	25%	115 VAC, 230 VAC				
			20	75%	115 VAC				
	4	400	10	75%	12 VDC, 24 VAC, 24 VDC	4/7	NEMA 4/7	460-3	230/460 VAC/3Ph (ER50 to 270 only)
			15	Std	115 VAC, 230 VAC				
			30	Ext'd	115 VAC				
	6 10	675 1000	15	Ext'd	12 VDC, 24 VAC, 24 VDC	24A		24A	24 VAC (24 VDC Rectified)
			30	25%	115 VAC, 230 VAC				
	15	1500	60	75%	115 VAC	12D		12D	12 VDC
			30	75%	115 VAC, 24 VAC, 24 VDC				
			12	100%	115 VAC, 230 VAC				
	20	2000	12	75%	24 VAC, 12 VDC, 24 VDC	24D		24D	24VDC
			14	100%	115 VAC, 230 VAC				
	38	3840	14	75%	24 VAC, 12 VDC, 24 VDC				
			38	100%	115 VAC, 230 VAC				
	50	5000	38	100%	115 VAC, 230 VAC				
70	7020	38	100%	230 VAC 3 phases					
120	11500	58	100%	24 VAC, 12 VDC, 24 VDC					
140	14040	58	100%	24 VAC, 12 VDC, 24 VDC					

Sample Ordering Schematic

How to Order							
Series	Size	Closing Time			NEMA	Motor	Option ⁴
ER	1	2.5			4	115	0

Notes:

1. See Technical Specifications (pp 2-5) for additional information on permissible actuator size, closing time, motor duty and motor voltage combinations
2. Cycle times are for nominal voltage and 60 Hz. Reduced voltage (for example, 110 VAC instead of 115 VAC, or 220 VAC instead of 230 VAC), and / or reduced frequency (for example, 50 Hz) can substantially increase closing times
3. Closing time / motor voltage specified determines motor duty
4. See Available Options (p 6) for option descriptions and ordering schematic codes
5. ER 115 VAC motor rated 75% duty for non-CSA certified applications

Figure 1 — ER1 NEMA 4

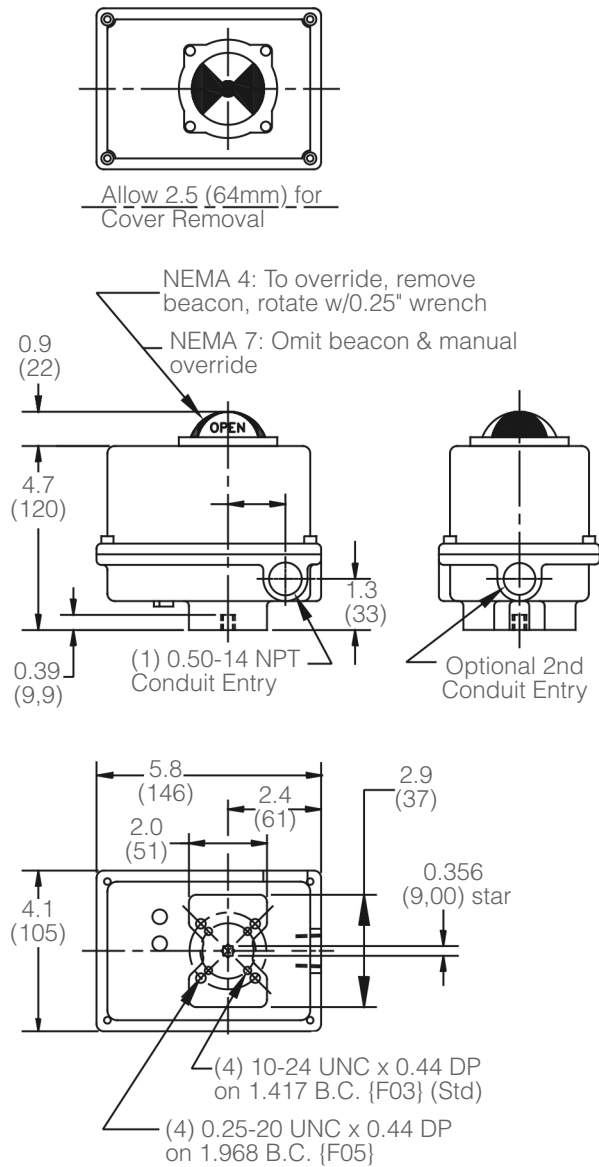
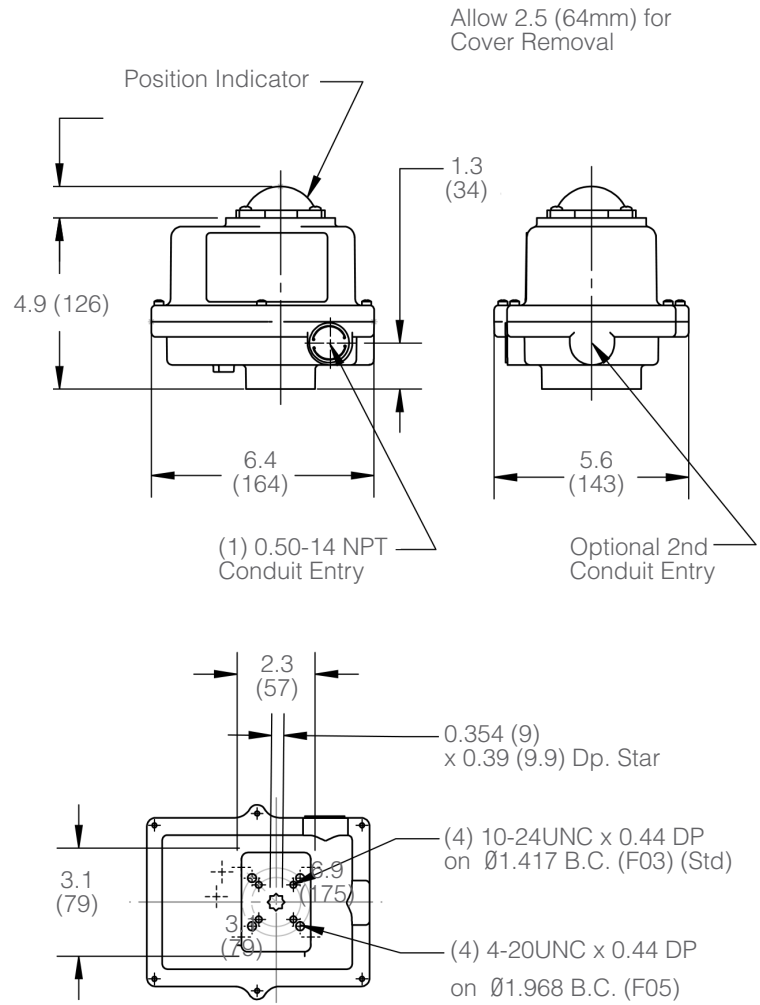

Figure 2 — ER1 NEMA 7



ART1323

CSA Certified NEMA 4, 7, 9

ART0877

The ER1 supplied with positioner normally uses the ER2 regular housing (Fig. 2 or 4) with a F03 bolt pattern and a 14 mm (F05) stem hole. If a 9 mm (F03) stem hole is required, the ER1 housing is used with a separate attached enclosure for the positioner.

CSA Certified NEMA 4 (except 115 VAC 75% duty)

Figure 3 — ER2 & 3 NEMA 4 Regular Housing

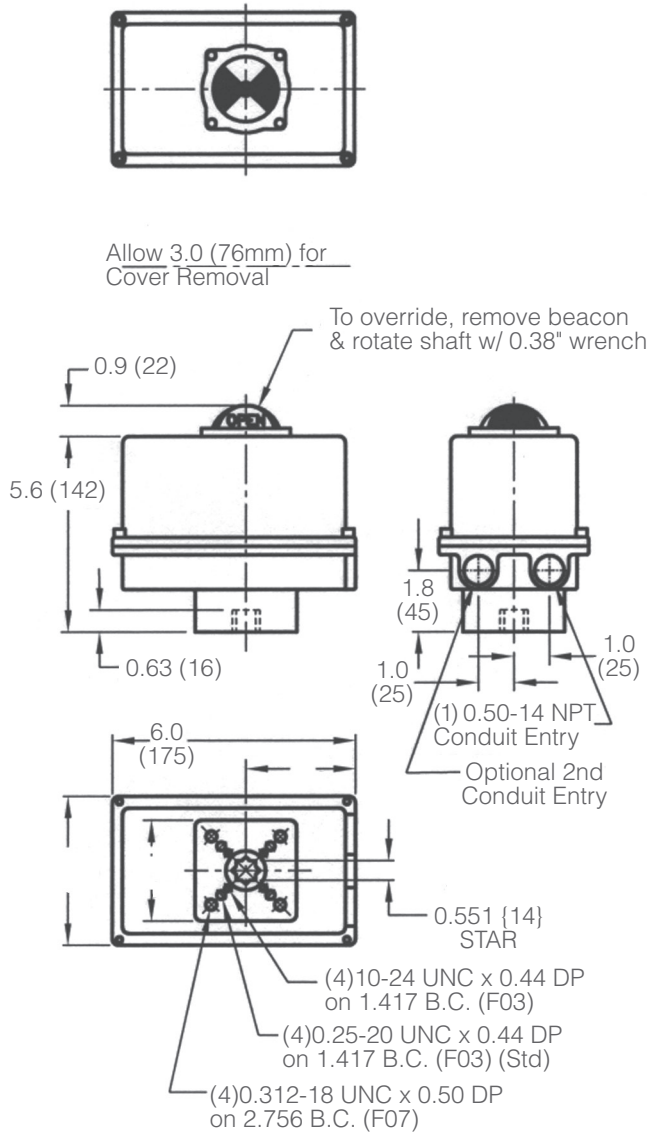

ART0878

CSA Certified NEMA 4 (except 115 VAC 75% duty)

Figure 4 — NEMA 2 & 3 NEMA 4 Deep Base Housing

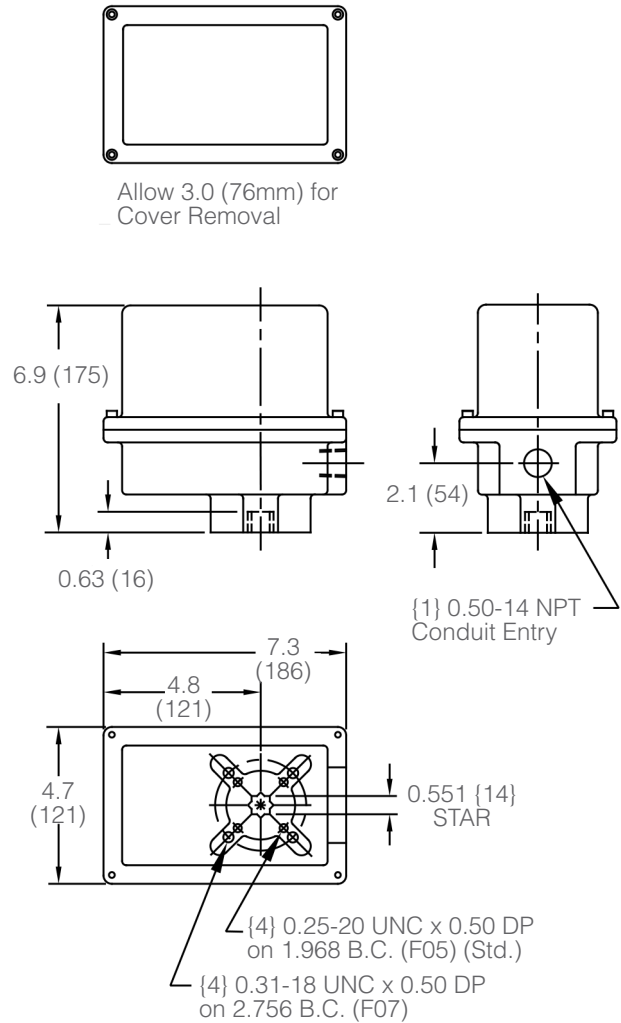

ART0879

The deep base housing is required for ER2 and ER3 NEMA 4 actuators with speed control, timer and 4-20 mA position out options

Figure 5 — ER2 & 3 NEMA 7

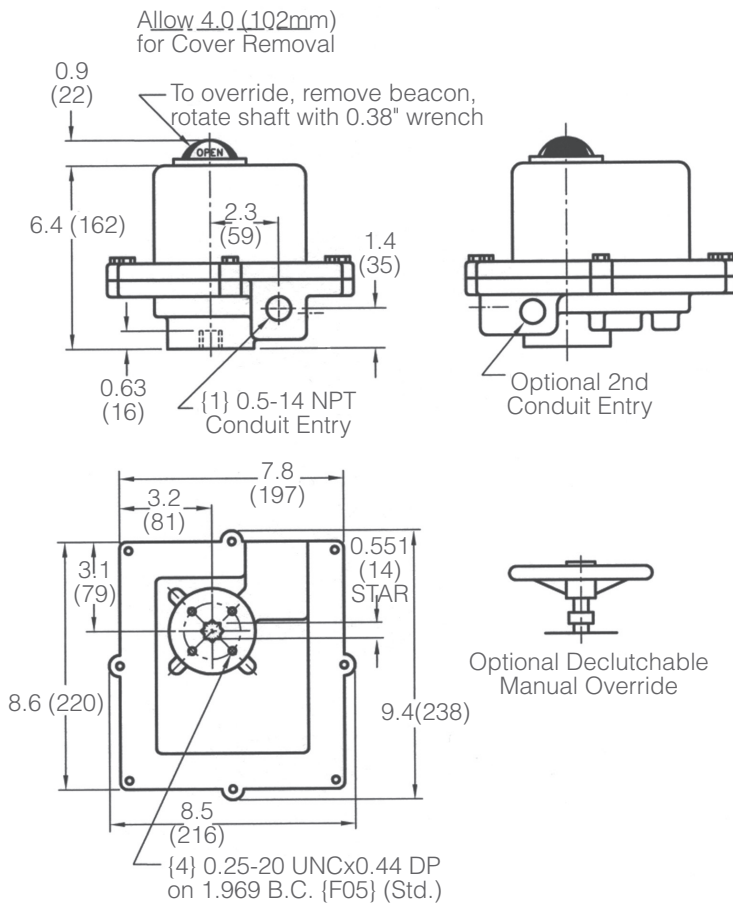

ART0880

Note: Allow 4.0" (102mm) for cover removal
CSA Certified NEMA 7

Figure 6 — ER4, 6, 10, 15 NEMA 4

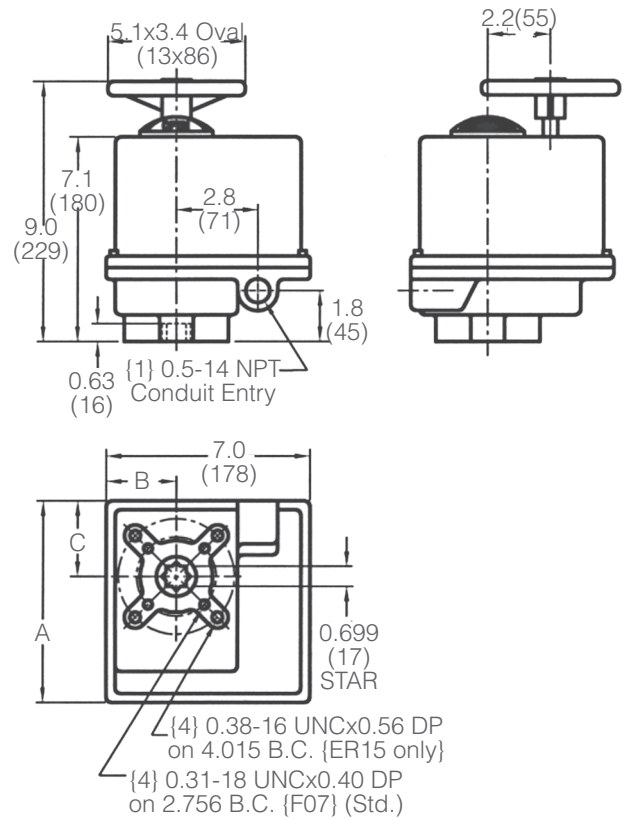

ART0881

Dimensions, Inches

Model	ER Series		
	Size	A	B
ER4, 6, 10	7.0	2.4	2.6
ER15	8.5	3.1	3.4

Dimensions, Metric

Model	ER Series		
	Size	A	B
ER4, 6, 10	178	60	67
ER15	216	79	86

Note: Allow 4.0" (102mm) for cover removal
CSA Certified NEMA 4

Figure 7 — ER4, 6, 10, 15 NEMA 7

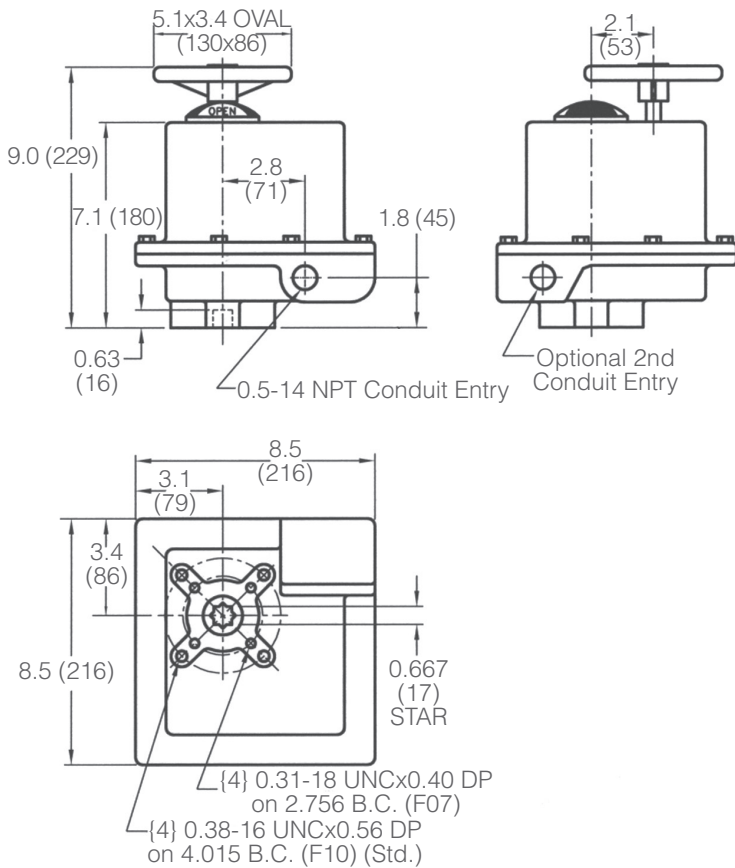

ART0882

Note: Allow 4.0" (102mm) for cover removal
CSA Certified NEMA 7

Figure 8 — ER20 & 38

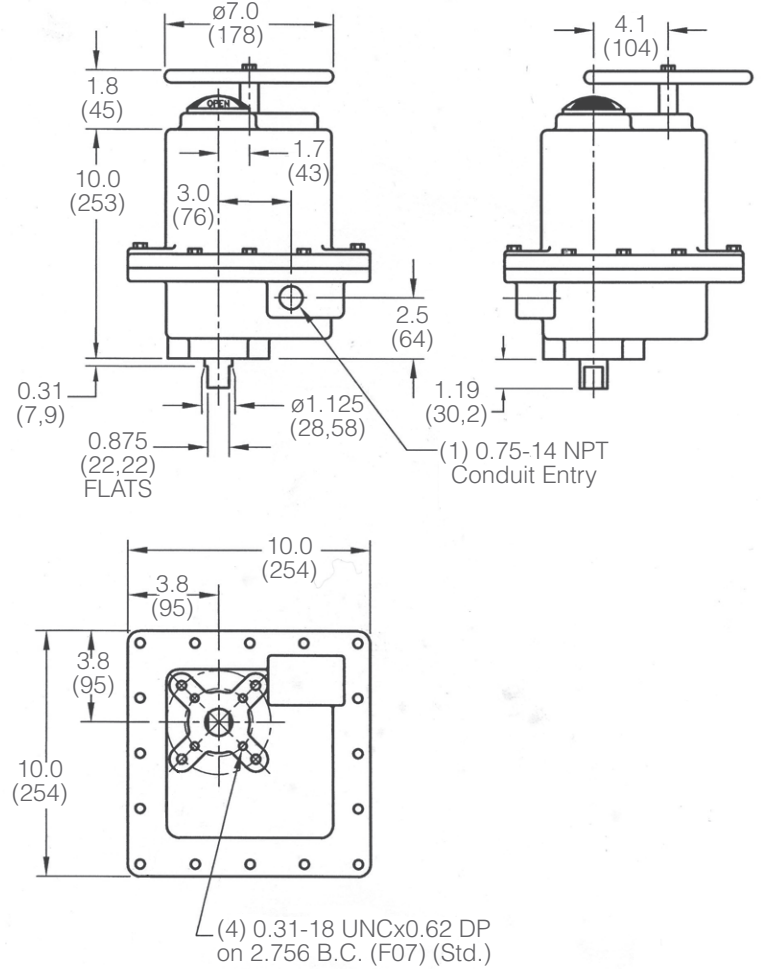

ART0883

Note: Allow 6.0" (152mm) for cover removal

Figure 9 — ER50, 70, 120 & 140

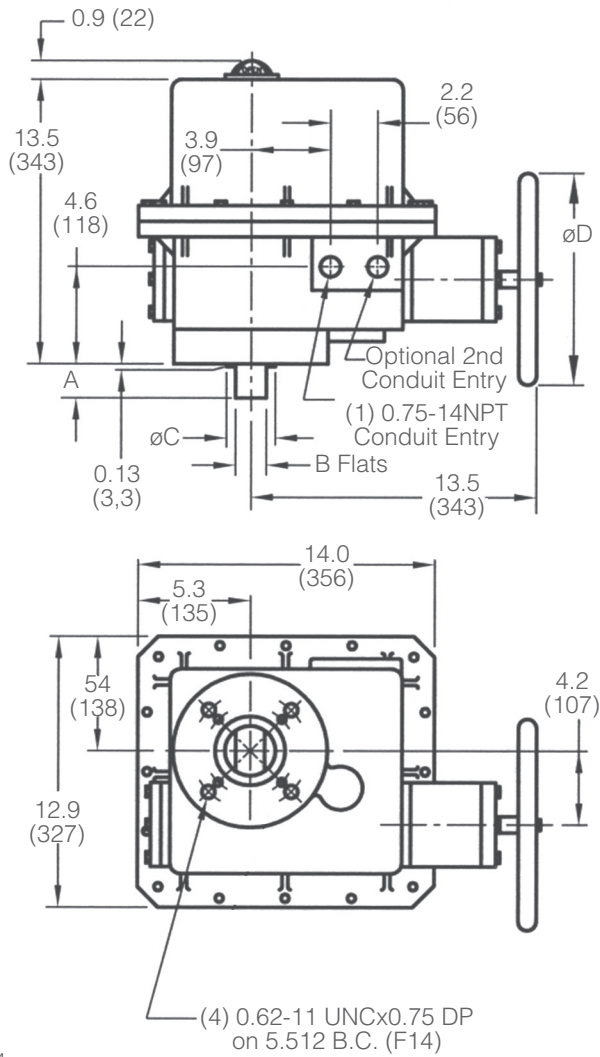

ART0884

Dimensions, Inches				
Model	ER Series			
Size	A	B	C	D
ER50 (5K)	1.19	0.875	1.125	10.0
ER70 (7K)	1.60	1.422	2.375	10.0
ER120 & 140 (12K & 14K)	1.60	1.422	2.375	16.0

Dimensions, metric				
Model	ER Series			
Size	A	B	C	D
ER50 (5K)	30,2	22,2	28,6	254
ER70 (7K)	40,6	36,1	60,3	254
ER120 & 140 (12K & 14K)	40,6	36,1	60,3	406

Note: Allow 7.0" (178mm) for cover removal

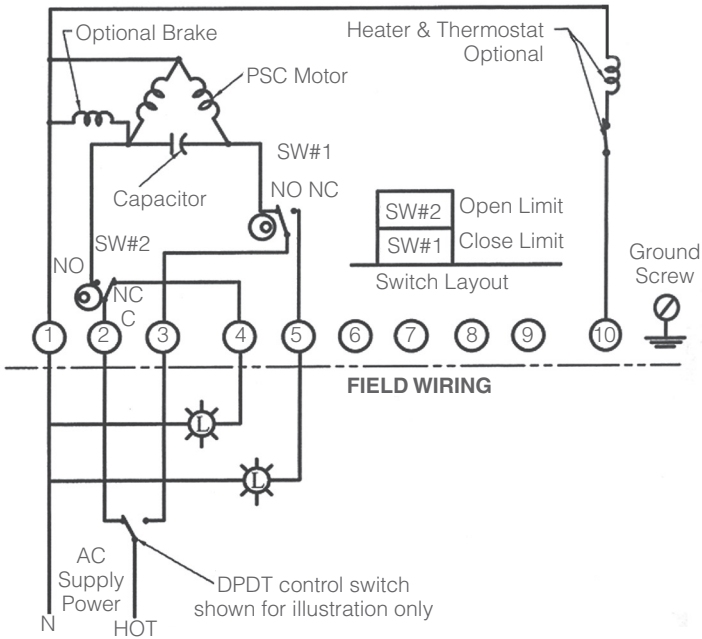
Basic Actuator

26-01275

Notes:

- Power to terminals 1 & 2 opens valve (CCW rotation)
- Power to terminals 1 & 3 closes valve (CW rotation)
- Terminals 4 & 5 for light indication

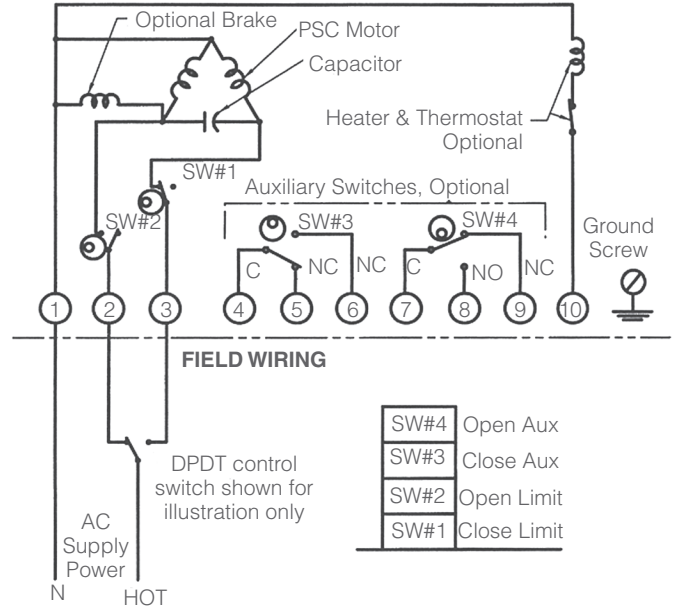
Actuator with Two Auxiliary Switches

26-01276

Notes:

- Power to terminals 1 & 2 opens valve (CCW rotation)
- Power to terminals 1 & 3 closes valve (CW rotation)
- Terminals 4 through 9 for auxiliary switch connection

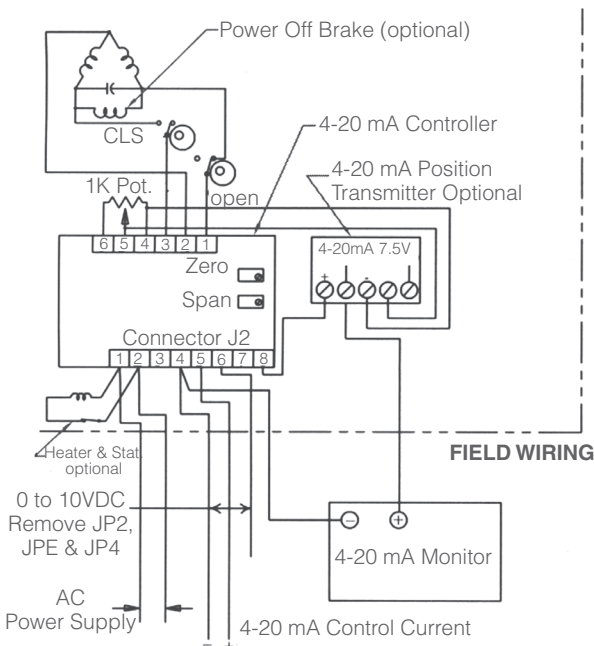
Actuator with 4-20 mA Positioner and Position Transmitter

Notes:

The limit switches and feedback potentiometer have been calibrated at the factory and should not require further adjustments.

After mounting the actuator to the valve, calibrating the open & close position is performed by using the zero (4 mA) and span (20 mA) trim potentiometers.

The 1K Pot. shown is used internally by the controller and optional position transmitter, and cannot be used for external indication. A second (dual) Pot. is available for external position indication.

26-01280

Marwin Valve

A Division of Richards Industries, 3170 Wasson Road, Cincinnati, OH 45209
 toll free. 800.543.7311, local. 513.533.5600, fax. 513.871.0105
www.marwinvalve.com



Vinnova Exploration
 sales@vinnova.asia
 063-271-9119
www.vinnova.asia