



## World Class Clampseal® Swivldisc Gate Valves

- *Swivldisc Wedge Gate*
- *Pressure Seat Bonnet*
- *In-line Repairable*
- *High-performance Graphite Packing*



**Conval Clampseal® Swivldisc Gate Valves are designed for the world's most demanding high-pressure, high-temperature applications.**



**STANDARD SIZES**

1/2" through 4"

**PRESSURE RATING**

ASME Class 1500 and 2500

**STANDARD MATERIALS**

Carbon Steel 216 GR WCB

Other materials available upon request

**STANDARD ACCESSORIES**

Bypass

Actuators - Air or Motor



**DESIGN FEATURES**

**Swivldisc Wedge Gate Design**

The Conval Swivldisc wedge gate design employs a flexible disc which permits the seating surfaces to achieve perfect alignment, establishing a tight seal not possible with standard wedge gates.

**Pressure Seal Bonnet**

The simple and effective pressure seal bonnet provides ready access for servicing with no welds to cut or seal rings or gaskets to replace. The body-to-bonnet joint integrity is maintained through countless thermal cycles.

**High-performance Graphite Packing**

The packing system delivers the best performance available. The one-piece gland with integral gland wrench is readily adjustable at any time. The fine finish of the stem and chamber combines with high-performance graphite packing to ensure long packing service life.

**In-line Servicing**

With the Conval Swivldisc gate valve, repacking can be accomplished by swapping the bonnet-chamber with the fresh pre-packed unit.

**Two-Year Warranty**

Conval is committed to unsurpassed quality. We are so confident of the quality of our product, that we offer a two-year warranty.

# SPECIFICATIONS

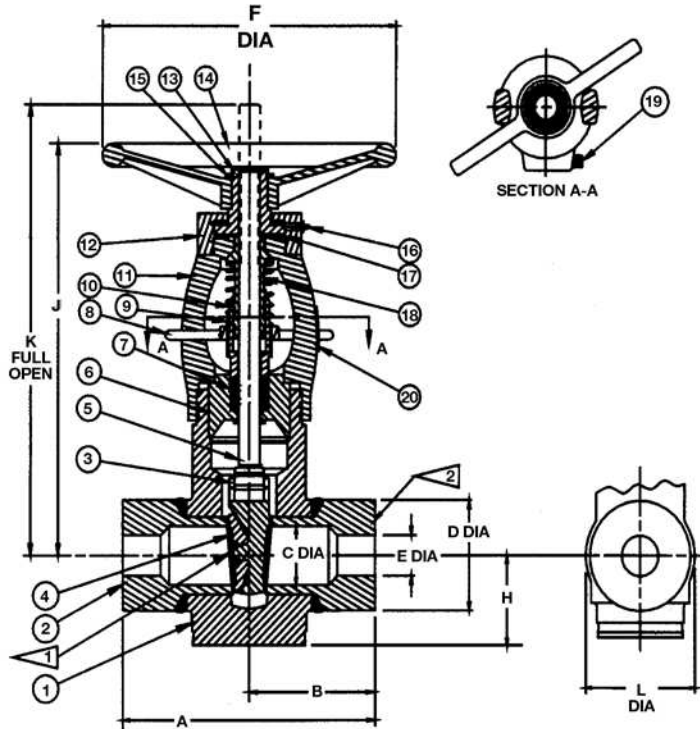

## MATERIALS

No.	Name	Qty.	Material	Specification
1	Body	1	Carbon Steel	ASME SA-216 GR WCB
2	Hub	2	Carbon Steel	ASME SA-696 GR. C
3	Gate	1	Stainless Steel Cobalt Alloy	ASME SA-479 TYPE 410
4	Disc	1	Cobalt Alloy	
5	Stem	1	Stainless Steel	ASTM A582-TYPE 416
6	Bonnet	1	Stainless Steel	ASME SA-479 TYPE 410
7	Packing	SET	Graphite Rings	HIGH DENSITY GRAPHITE
8	IGW	1	Cast Stainless	Stainless Steel
9	Spring	1	Stainless Steel	Mfg. Std.
10	Gland	1	Stainless Steel	ASTM A582-TYPE416
11	Yoke	1	Carbon Steel	ASME SA-216 GR WCB/SA-105
12	Bearing Cap	1	Carbon Steel	Mfg. Std.
13	Stem Nut	1	Aluminum Bronze	ASME SB-150 UNS C64200
14	Handwheel	1	Iron/Steel	Mfg. Std.
15	Retaining Ring	1	Stainless Steel	Mfg. Std.
16	Grease Fitting	1	Stainless Steel	Mfg. Std.
17	Bearing Set	2	Commercial	Mfg. Std.
18	Yoke Bushing	1	Aluminum Bronze	ASME SB-150 UNS C64200
19	Clampbolt	1	Stainless Steel	Mfg. Std.
20	ID Plate	1	Stainless Steel	Mfg. Std.

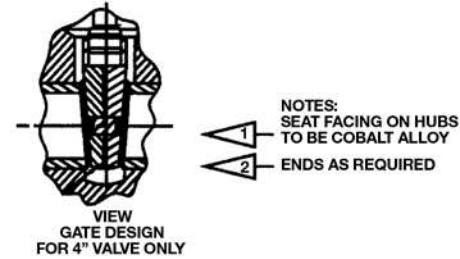

Pressure Class	Size Code	Pipe Size	Valve Outline Dimensions										Flow Cv
			A	B	C	D	E	F	H	J	K	L	
1500	2E	1/2	5 1/2	2 3/4	0.815	2 1/16	0.466	6	1 3/4	9	9 1/4	2 7/8	15
		15	140	70	21	52	12	152	45	229	235	73	
	2E	3/4	5 1/2	2 3/4	0.815	2 1/16	0.612	6	1 3/4	9	9 1/4	2 7/8	25
		20	140	70	21	52	16	152	45	229	235	73	
	2E	1	5 1/2	2 3/4	0.815	2 1/16	0.815	6	1 3/4	9	9 1/4	2 7/8	45
		25	140	70	21	52	21	152	45	229	235	73	
	3G	1 1/2	7	3 1/2	1.338	3	1.338	8	2 1/8	12 7/8	13 5/8	3 1/2	131
		40	178	95	34	80	34	203	54	327	346	95	
4J	2	8 1/2	4 1/4	1.689	3 3/4	1.689	10	2 7/8	15 3/4	16 5/8	4 3/4	225	
	50	215	108	43	95	43	254	73	400	422	120		
5L	2 1/2	10	5	2.300	5 1/8	2.125	14	4	19 5/8	20 1/2	7	348	
	65	250	125	58	130	54	356	100	498	515	178		
6N	3	12	6	2.624	5 1/4	2.624	14	4	19 5/8	20 5/8	7	535	
	80	300	150	67	133	67	356	100	498	524	178		
8R	4	16	8	3.438	6 3/4	3.438	14	4 3/4	22 1/2	25 1/2	7 1/2	958	
	100	400	200	87	170	87	356	120	565	648	191		
2500	2D	1/2	7 5/16	3 21/32	0.599	2 5/32	0.252	6	1 3/4	9	9 1/4	2 7/8	4
		15	186	93	15	55	6	152	45	229	235	73	
	2D	3/4	7 5/16	3 21/32	0.599	2 5/32	0.434	6	1 3/4	9	9 1/4	2 7/8	12
		20	186	93	15	55	11	152	45	229	235	73	
	2D	1	7 5/16	3 21/32	0.599	2 5/32	0.599	6	1 3/4	9	9 1/4	2 7/8	23
		25	186	93	15	55	15	152	45	229	235	73	
	3F	1 1/2	9 1/8	4 9/16	1.100	3	1.100	8	2 1/8	12 7/8	13 5/8	3 1/2	81
		40	232	116	28	80	28	203	54	327	346	95	
	4H	2	11	5 1/2	1.503	3 3/4	1.503	10	2 7/8	15 3/4	16 3/8	4 3/4	157
		50	279	140	38	95	38	254	73	400	416	120	
5K	2 1/2	13	6 1/2	2.300	5 1/8	1.771	14	4	19 5/8	20 1/2	7	240	
	65	330	165	58	130	45	356	100	498	521	178		
6M	3	14 1/2	7 1/4	2.300	5 1/8	2.300	14	4	19 5/8	20 1/2	7	405	
	80	365	184	58	130	58	356	100	498	521	178		
8P	4	18	9	3.152	6 1/4	3.152	14	4 3/4	22 1/2	24 1/2	7 1/2	806	
	100	450	229	80	158	80	356	120	565	622	191		

Numbers shown in Black indicate dimensions in inches, weight in pounds. Numbers shown in blue indicate dimensions in mm.

## The Conval Story

In 1962, Mr. Chester Siver completed designs for a revolutionary line of high-pressure, forged steel valves. Hamilton Standard (now Hamilton Sunstrand), a division of United Technologies Corporation, was asked to use their then-new Electron Beam Welding technology for joining of parts into valves for subassemblies. Hamilton Standard became intrigued with the valve as an ideal application of the Electron Beam Welding technique, and negotiated a contract for the rights to manufacture and sell the valve. Mr. Siver served as manager of the valve project.



The first CLAMPSEAL® valves were introduced to the market by Hamilton Standard in 1964. However, in the mid-1960's, growing demand for the firm's popular aerospace products forced Hamilton Standard to make the decision to abandon its industrial products projects. The rights to the CLAMPSEAL valve reverted back to Mr. Siver. Since CLAMPSEAL valves were born in Connecticut, Mr. Siver founded "Conval" (short for Connecticut Valve) in 1967. Today, the valves are still manufactured in Connecticut, a state with a longstanding reputation for technological innovation and manufacturing excellence.

Founded in 1967, Conval has grown into a leader in valves for the world's most demanding applications. We have a global team of experts to help to meet your most challenging needs. We invite you to contact us today.

High-pressure, high-temperature ball, bellows, bonnetless, check, gate, globe, throttling, and urea service valves for the world's most demanding applications.



*Thank you for your business!*  
*ISO 9001 certified since 1992*  
*PED certified since 2003*  
*Nuclear N-stamp since 2006*



# Conval INC.

World Headquarters: 96 Phoenix Avenue, Enfield, CT 06082

Phone (860) 749-0761 Fax (860) 763-3557

e-mail: [sales@Conval.com](mailto:sales@Conval.com) [www.Conval.com](http://www.Conval.com)



**Vinnova Exploration**  
[sales@vinnova.asia](mailto:sales@vinnova.asia)  
063-271-9119  
[www.vinnova.asia](http://www.vinnova.asia)

Conval's policy is one of continuous development and improvement. Every effort is made to produce up-to-date literature but this catalog should not be regarded as an infallible guide to current specifications and does not form part of any contract. Conval reserves the right to make product improvements and changes without prior notice.