

708MV Series Motor Valve

CRN Registration Number Available

FRACTIONAL FLOW CONTROL VALVES

The Mark 708MV offers several advantages including extreme accuracy, high turndown ratios and repeatability. The features of this high resolution, low hysteresis digitally controlled motor makes the MK708MV a premiere control valve for applications involving chemical injection, dosing, pilot plants and research labs. In addition, it is a prime valve for skid builders.

Additional features of the MK708MV include a switch-selectable power supply, a hand drive mechanism for manual operation, and a 4-20 mA current input signal. Upon loss of input (not loss of power), the motor is designed to either lock in place, or fail to minimum input signal position.

FEATURES

- Spring-loaded TFE/Chevron packing – the spring-loaded packing maintains a proper compression, while minimizing excessive friction. This alleviates the need for most field adjusting. The TFE packing is suitable for temperatures to 450°F (232°C), while braided or Graphite/Grafoil may be used for higher temperature requirements.
- Bolted body/bonnet connection – the bolting provides solid construction and secure connection. This bolting adds ease to maintenance, as bonnet/actuator assembly may be removed with the valve body in-line.
- Guided trim – extended orifice and plug guiding are standard and offers improved shutoff and accuracy equivalent to heavy duty trim option of competitors (not applicable to cv's below 0.05).
- Manual operation by hand knob
- Output shaft with soft seating mechanism
- 4-20mA position feedback possible with standard motor (requires customer supplied external 12-36 power supply and a load connected in series with one lead from power supply)
- Unrestricted modulating duty



A Division of
Richards Industrials
3170 Wasson Road
Cincinnati, OH 45209

lowflow@richardsind.com
513.533.5600
www.lowflowvalve.com

MK708MV SERIES SPECIFICATIONS

Sizes: 1/4", 1/2", 3/4", 1" (DN8, DN15, DN20, DN25)

End Connections

- Threaded – NPT, BSPT, BSPP
- Socket weld
- Integral tube ends (max Cv of 0.2)
- Welded flanges (ANSI, DIN, JIS)

Body/Bonnet Materials

- Carbon Steel
- Stainless Steel
- Hastelloy C
- Hastelloy B
- Alloy 20
- Monel
- Titanium
- Other materials upon request

Trim Materials

- Cv's 0.05 (0,04 Kv) and above: 17-4 plug, 316SS & seat
- Cv's below 0.05 (0,04 Kv): Nitronic 60 stem/plug & seat

Optional Trim Materials

- 17-4 plug, 416SS seat
- Stellite plug and Stellite seat (hard seat only)
- 316Ss stem/plug & seat

Stem Packing

- Standard: spring-loaded TFE/Chevron (to 450°F/232°C)
- Optional: braided or Graphite/Grafoil (CML-250 required)

Body/Bonnet Gasket: RPTFE or Grafoil (matches packing material unless specified)

Service: steam, air, gas, oil, water, chemicals

Shutoff

- Standard – Cv's 0.05 and greater: ANSI Class IV; Cv's 0.02 and lower: ANSI Class VI
- Optional – Cv's 0.05 and greater: ANSI Class VI (with PEEK seats)

Action

- Direct (increasing signal closes valve)
- Reverse (increasing signal opens valve)

Flow Characteristic: linear (all Cv's), equal percentage (Cv ≥ 0.05/0,43 Kv only); or quick opening (Cv ≥ 0.05/0,43 Kv only)

Maximum Allowable ΔP Rating

Motor Actuator	Valve Cv (Kv)				
	3.0-4.0 (2,6-3,4)	1.25-2.0 (1,0-1,7)	0.32-1.0 (0,27-0,86)	0.05-0.2 (0,04-0,86)	≤ 0.02 (≤ 0,017)
CML100	500	800	2550	5000	5000
CML250	1050	1750	5000	5000	5000

Cv (Kv) Selection

4.0** (3,4)	3.0**(2,6)	2.0* (1,7)	1.25* (1,1)	1.0 (0,9)
0.5 (0,43)	0.2 (0,17)	0.1 (0,09)	0.05 (0,04)	0.02 (0,017)
0,01 (0,009)	0,005 (0,00043)	0,002 (0,0017)	0,001 (0,0009)	0,0005 (0,00043)
0,0002 (0,00017)	0,0001 (0,00009)	0,00005 (0,000043)	0,00002 (0,000017)	0,00001 (0,000009)

* 0.5" body only

** 0.75" body only

Pressure & Temperature Ratings

Temp F° (°C)	1/4" & 1/2" (DN8 & 15) Body/Bonnet psi (bar)		3/4" (DN20) Body/Bonnet psi (bar)	
	CF8M, SST	A105, CS	CF8M, SST	A105, CS
100 (38)	5000 (345)	5000 (345)	4000 (276)	4000 (276)
200 (93)	4299 (296)	4555 (314)	3439 (237)	3644 (251)
300 (149)	3882 (268)	4426 (305)	3106 (214)	3541 (244)
400 (204)	3569 (246)	4278 (295)	2855 (199)	3422 (236)
500 (260)	3319 (229)	4042 (279)	2655 (183)	3234 (223)
600 (316)	3132 (216)	3691 (254)	2506 (173)	2953 (204)
650 (343)	3083 (213)	3623 (250)	2466 (170)	2898 (200)
700 (371)	3000 (207)	3596 (248)	2400 (165)	2877 (198)
750 (399)	2931 (202)	3401 (234)	2345 (162)	2721 (188)
800 (427)	2882 (199)	2780 (192)	2306 (159)	2224 (153)
850 (454)	2819 (194)	—	2255 (155)	—
900 (482)	2736 (189)	—	2189 (151)	—
950 (510)	2681 (185)	—	2145 (148)	—
1000 (538)	2528 (174)	—	2022 (139)	—

MK708MV SERIES MOTOR SPECIFICATIONS & DIMENSIONS**Electrical**

- Line Voltage: 120/240VAC (switch selectable) & 24VDC (contact factory)
- Conduit Entry: two 3/4" NPT or M25
- Frequency: 50/60 Hz
- Current: 0.06 / 0.49 @ 120VAC
- Command Signal Input:
 - Current: 4-20mA
 - Optional control methods available upon request
- Optional Supercapacitor Power Backup

Mechanical

- Max thrust:
 - CML-100: 100 lb. (0,4 Kn)
 - CML-250: 250 lb. (1,1 Kn)
- Speed:
 - CML-100: 0.125 to 0.25"/sec (3,18 - 6,4 mm/sec)
 - CML-250: 0.065 to 0.13"/sec (1,59 - 3,18 mm/sec)
- Action: direct or reverse

Environmental

- Temperature Limits:
 - CML-100: -4F to +150F (-20C to +66C)
 - CML-250: -4F to +150F (-20C to +66C)
 - Optional low temperature trim for CML motors -40F to +150F (-40C to +66C)
- Enclosure:
 - Explosion-proof for Class I, Div. 1, Group C & D
 - Dust-ignition-proof for Class II, Div. 1, Group E, F, G
 - CML-100 / CML-250: Nema 4 & 6 (IP67), indoor or outdoor
- Approvals
 - CML-100 / CML-250: FM approval is standard with motor, for all other approvals please consult factory

Field Selectable Adjustments

- deadband
- zero & span
- command signal
- manual / auto operation
- output shaft position on loss of command signal
- adjustable speed

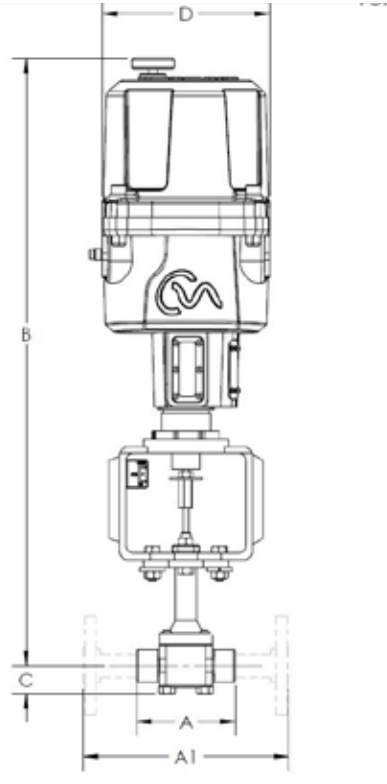
MK708MV SERIES DIMENSIONS - CML 100 / CML 250

- Mark 708MV Series Threaded & FSW Ends, Inches**

VALVE SIZE	DIMENSIONS, INCHES				WEIGHT LBS
	A	B*	C	D	
1/4"	3.50	21.48	0.9	7.09	27.3
1/2"	3.50	21.48	0.9	7.09	27.3
3/4"	4.38	21.48	1.2	7.09	29.6
1"	4.38	21.58	1.2	7.09	29.6

- Mark 708MV Series Flanged Ends, Inches**

VALVE SIZE	ANSI FLANGE	DIMENSIONS, INCHES				WEIGHT LBS
		A1	B*	C	D	
1/2"	150#	7.25	21.48	0.9	7.09	29.3
	300#	7.50				31.3
3/4"	150#	7.25	21.48	1.2	7.09	33.3
	300#	7.62				35.6
1"	150#	7.25	21.58	1.2	7.09	33.3
	300#	7.25				35.6

- Mark 708MV Series Threaded & FSW Ends, Metric**

VALVE SIZE	DIMENSIONS, MM				WEIGHT KGS
	A	B*	C	D	
DN8	89	546,6	23	180	12,4
DN15	89	546,6	23	180	12,4
DN20	111	546,6	30	180	13,4
DN25	111	548,1	30	30	13,4

- Mark 708MV Series Flanged Ends, Metric**

VALVE SIZE	DIN FLANGE	DIMENSIONS, MM				WEIGHT KGS
		A1	B*	C	D	
DN15	10/16	184,2	545,6	23	180	13,3
	25/40	190,5				14,2
DN20	10/16	184,2	545,6	30	180	15,1
	25/40	193,5				16,2
DN25	10/16	184,2	548,1	30	180	15,1
	25/40	196,8				16,2

* An additional 5 3/4" (146mm) is needed to remove motor cover for electrical connections

MK708MV SERIES ORDERING SCHEMATIC

Model No.	Size	Body Mat'l	1	2	3	4	5	6	7	8	9	10	11	12	13	14	15

MODEL	
708MV	Motor Valve

SIZE	
025	1/4" (DN8)
050	1/2" (DN15)
075	3/4" (DN20)
100	1" (DN25)

BODY MATERIAL	
CS*	Carbon Steel (WCB)
S6*	Stainless Steel (CF8M)
HC*	Hastelloy C
MN*	Monel
A2*	Alloy 20

1 & 2 END CONNECTION	
PT	NPT
SW	FSW
F5	150# FE
F3	300# FE
TN	Integral Tube Nuts
ZZ	Non-Standard

3 & 4 TRIM	
T6	316SS/Teflon Packing
TM	Monel/Teflon Packing
TA	Alloy 20/Teflon Packing
G6*	316SS/Graphite
ZZ	Non-Standard

* CML-250 required

5 & 6 PLUG SEAT			
	Material of Stem/Plug/Seat		Cv
A	Standard - Linear Hard	A	0.00001
B	Standard =% Hard	B	0.00002
C	Standard Q.O. Hard	C	0.00005
D	Standard Linear Soft (PEEK)	D	0.0001
E	Standard =% Soft (PEEK)	E	0.0002
F	Standard Q.O. Soft (PEEK)	F	0.0005
M	316/Stellite/Stell-Lin. Hard	G	0.001
N	316/Stellite/Stell =% Hard	H	0.002
P	316/Stellite/Stell Q.O. Hard	I	0.005
		J	0.01
		K	0.02
		L	0.05
		M	0.1
		N	0.2
		P	0.5
		Q	1.0
		R	2.0
		S	4.0*
		T	3.0*
ZZ	Non-standard		

* 3/4" body only

7 & 8 RANGE	
NF	On-Off
42	4-20mA
41	4-12mA
12	12-20mA
V5	0-5V
V1	0-10V
ZZ	Non-Standard

9 & 10 DIAPHRAGM	
00	None

11 & 12 ACTUATOR	
C1*	CML100
C2*	CML250

* Standard factory setting is 120 VAC. Use accessory option 04 for 240 VAC.

13 & 14 ACCESSORIES	
00	None
XC	Oxygen Clean
04	Set Motor for 240 VAC

15 ACTION	
D	Direct
R	Reverse



Vinnova Exploration
 sales@vinnova.asia
 063-271-9119
 www.vinnova.asia