



708BS Series Bellows Stem Seal

Fractional Flow Control Valves

CRN Registration Number Available

FRACTIONAL FLOW CONTROL VALVES

Bellows stem seals eliminate fugitive emissions by surrounding the valve stem with a pressure-tight barrier, isolating the stem from the process fluid and preventing leakage to the atmosphere. For an extra measure of protection, the bellows stem seal option provides a back-up seal of Teflon, braided or Graphite/Grafoil packing along with a detection port for use in monitoring potential emissions leakage.

Features:

- Features standard bonnet port for use in lubricating the packing for added protection against leakage, or for use as a detection port for monitoring potential fugitive emissions
- Triple-ply bellows provides added strength and enhanced performance

SPECIFICATIONS

Sizes: 1/4", 1/2", 3/4" (DN8, DN15, DN20)

End Connections

- Threaded – NPT, BSPT, BSPP
- Socket weld – 1/2" & 3/4" only (DN15 & DN20)
- Integral tube ends (max Cv of 0.2)
- Flanged

Actuator (Positioner required with all actuators)

- 1/4" & 1/2" (DN8 & 15) – standard: 14M (14in²) multi-spring; optional: 35M (35in²) multi-spring
- 3/4" (DN20) – standard: 14M; optional 35M

Body/Bonnet Materials

- Carbon Steel
- Stainless Steel
- Hastelloy C
- Hastelloy B
- Alloy 20
- Monel
- Titanium



A Division of
Richards Industrials
3170 Wasson Road
Cincinnati, OH 45209

lowflow@richardsind.com
513.533.5600
www.lowflowvalve.com



Vinnova Exploration
sales@vinnova.asia
063-271-9119
www.vinnova.asia

MK708BS SERIES BELLOWS STEM SEAL SPECIFICATIONS (CON'T)

Trim Material

- Standard trim – Cv's 0.05 (0,04 Kv's) & above: 17-4 plug, 316SS stem and seat; Cv's below 0.05 (0,04 Kv's): Nitronic 60 stem, plug and stem
- Optional trim – 17-4 plug, 416SS seat; Stellite plug and seat; 316SS stem, plug and seat

Bellows Material

- Standard – 316L, Triple-ply
- Optional – Hastelloy C

Actuator Material: Aluminum

Diaphragm Material

- 14M Actuator: Nylon/Nitrile
- Optional 35M Actuator: Buna-N fabric reinforced

Stem Packing Material

- Standard – spring-loaded TFE/Chevron
- Optional – braided or Graphite/Grafoil with positioner

Gasket Material: matched to packing material

Service: Steam, air, gas, chemicals, oil, water

Shutoff

- Standard – Cv's 0.05 and greater: ANSI Class IV; Cv's 0.02 and lower: ANSI Class VI
- Optional – Cv's 0.05 and greater: ANSI Class VI (with PEEK seats)

Ranges: 3-15 (0,2-1,0); 6-30 (0,4-2,1); 3-9 (0,2-0,6) psi (bar)
positioner required on all ranges

Mark 15 TMP standard. Consult factory for smp configuration

Valve Action

- Direct (ATC)
- Reverse (ATO)

Flow Characteristics: linear (all Cv's), equal percentage (Cv > 0.05/0,43 Kv only); or quick opening (Cv > 0.05/0,43 Kv only)

Cv (Kv) Selection

4.0** (3,4)	2.0* (1,7)	1.25* (1,1)	1.0 (0,9)	0.5 (0,43)
0.2 (0,17)	0.1 (0,09)	0.05 (0,04)	0.02 (0,017)	0.01 (0,009)
0.005 (0,00043)	0.002 (0,0017)	0.001 (0,0009)	0.0005 (0,00043)	0.0002 (0,00017)
0.0001 (0,00009)	0.00005 (0,000043)	0.00002 (0,000017)	0.00001 (0,000009)	

* Available in 1/2" & 3/4" sizes (DN15 & DN20) only

** Available in 3/4" size (DN20) only

Consult factory for lower Cv (Kv) values

Maximum Allowable ΔP Ratings

Cv (Kv)	14M Actuator		35M Actuator	
	ATO w/pos. @ 40 psi (2,8 bar)	ATCw/pos @ 40 psi (2,8 bar)	ATC w/pos. @ 40 psi (2,8 bar)	ATC w/pos. @ 40 psi (2,8 bar)
4.0 (3,4)	532 (37)	1500 (103)	880 (61)	1500 (103)
1.25-2.0 (1,1-1,7)	800 (55)	1500 (103)	1323 (91)	1500 (103)
0.32-1.0 (0,3-0,9)	1500 (103)	1500 (103)	1500 (103)	1500 (103)
0.05-0.2 (0,04-0,17)	1500 (103)	1500 (103)	1500 (103)	1500 (103)
<0.02 (0,017)	1500 (103)	1500 (103)	1500 (103)	1500 (103)

* Consult factory if P2 is greater than 250 psig

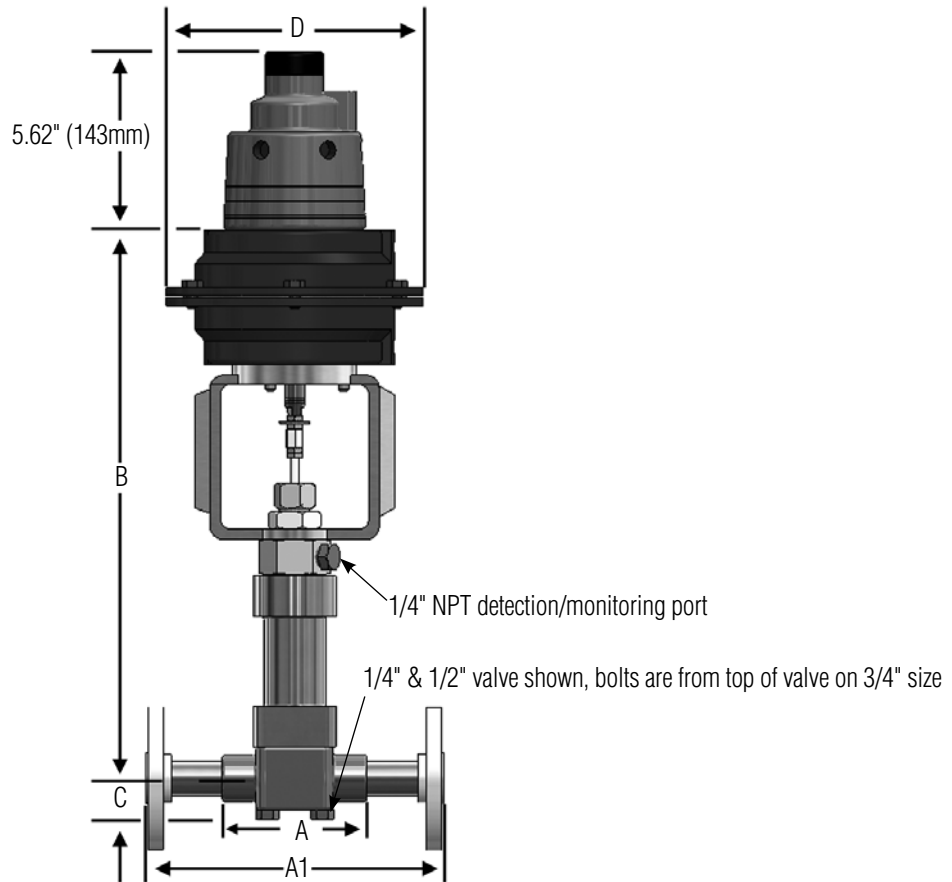
MK708BS SERIES BELLOWS STEM SEAL DIMENSIONS

- Mark 708BS Series Threaded Ends**

VALVE SIZE	ACTUATOR	DIMENSIONS, INCHES				WEIGHT LBS
		A	B	C	D	
1/4"	14M	3.50	13.48	0.9	6.3	9.5
1/2"	14M	3.50	13.48	0.9	6.3	9.5
3/4"	14M	4.38	13.54	1.2	6.3	14.5
	35M	4.38	15.34	1.2	9.5	23.5

- Mark 708BS Series Flanged Ends**

VALVE SIZE	ANSI FLANGE	DIMENSIONS, INCHES				WEIGHT LBS
		A1	B	C	D	
1/2" (14M)	150#	7.25	13.48	0.9	6.3	11.5
	300#	7.50	13.48	0.9	6.3	13.5
3/4" (14M)	150#	7.25	13.54	1.2	6.3	18.5
	300#	7.62	13.54	1.2	6.3	19.5
3/4" (35M)	150#	7.25	15.34	1.2	9.5	27.5
	300#	7.62	15.34	1.2	9.5	28.5

- Mark 708BS Series Threaded Ends, Metric**

VALVE SIZE	ACTUATOR	DIMENSIONS, MM				WEIGHT KGS
		A	B	C	D	
8	14M	89	342	23	160	4,3
15	14M	89	342	23	160	4,3
20	14M	111	344	30	160	6,6
	35M	111	390	30	241	10,7

- Mark 708BS Series Flanged Ends, Metric**

VALVE SIZE	FLANGE PN	DIMENSIONS, MM				WEIGHT KGS
		A1	B	C	D	
1/2"	10/16	130	342	23	160	5,2
	25/40	150	342	23	160	6,1
3/4"	10/16	184	344	30	160	8,4
	25/40	194	344	30	160	8,8
3/4"	10/16	184	390	30	241	12,5
	25/40	194	390	30	241	13,0

MK708BS SERIES BELLOWS STEM SEAL DIMENSIONS

Model No.	Size	Body Mat'l	1	2	3	4	5	6	7	8	9	10	11	12	13	14	15	16

MODEL	
708BS	Bellows Seal w/ Top Mount Positioner
708BSSP	Bellows Seal w/ Side Mount Positioner

SIZE	
025	1/4" (DN8)
050	1/2" (DN15)
075	3/4" (DN20)

BODY MATERIAL	
CS*	WCB Carbon Steel
CB*	A105 Carbon Steel Barstock
S6*	CF8M Stainless Steel
SB*	316/ 316L Stainless Steel Barstock
HC*	Hastelloy C
MN*	Monel
A2*	Alloy 20

1 & 2 END CONNECTIONS	
PT	NPT
SW	FSW
F5	150# FE
F3	300# FE
TN	Integral Tube Nuts
ZZ	Non-standard

3 & 4 TRIM	
B6	316SS/Teflon Packing
BC	Hastelloy C/Teflon Packing
G6	316SS/Graphite
ZZ	Non-standard

5 & 6 PLUG SEAT		
	Material of Stem/Plug/Seat	Cv
A	Standard - Linear Hard	A 0.00001
B	Standard =% Hard	B 0.00002
C	Standard Q.O. Hard	C 0.00005
D	Standard Linear Soft (PEEK)	D 0.0001
E	Standard =% Soft (PEEK)	E 0.0002
F	Standard Q.O. Soft (PEEK)	F 0.0005
M	316/Stellite/Stell-Lin. Hard	G 0.001
N	316/Stellite/Stell =% Hard	H 0.002
P	316/Stellite/Stell Q.O. Hard	I 0.005
		J 0.01
		K 0.02
		L 0.05
		M 0.1
		N 0.2
		P 0.5
		Q 1.0
		R 2.0
		S 4.0
		T 3.0
ZZ	Non-standard	

7,8,9,10 ACTUATOR			
	Range	Diaphragm	Actuator
A4T4	3-15 DIR	Nylon/Nitrile	14M
B4T4	3-15 REV		
C4T4	3-9 DIR		
D4T4	3-9 REV		
E4T4	9-15 DIR		
F4T4	9-15 REV		
G4T4	6-30 DIR		
H4T4	6-30 REV		
A3B3	3-15 DIR	Buna-N	35M
B3B3	3-15 REV		
C3B3	3-9 DIR		
D3B3	3-9 REV		
E3B3	9-15 DIR		
F3B3	9-15 REV		
G3B3	6-30 DIR		
H3B3	6-30 REV		
ZZ	Non-Standard		

6-30 bench set, 35 psi minimum & 40 psi maximum supply pressure to positioner

11 & 12 ACTUATOR FEATURE			
	Action		Actuator
D	Direct	4	14M
R	Reverse	3	35M
S	SMP		

MK708BS SERIES BELLOWS STEM SEAL DIMENSIONS

13 & 14	ACCESSORIES
00	None
A5	Air Regulator on 35M
A7	Air Regulator on 14M
TG	TFE Gasket
G2	Two Gages on TMP
SH	304SS Strain Hardened
S2	3-way Solenoid Energize to Open
X2	Exp. Proof 3-way Solenoid Energize to Open
S3	3-way Solenoid Energize to Close
X3	Exp. Proof 3-way Solenoid Energize to Close
XC	Oxygen Clean
ZZ	Non-standard

15	ACTION
D	Air-to-close
R	Air-to-open

16	I/P
0	None
4	I/P 14M Act. 4-20Ma/3-15 psi
3	I/P 35M Act. 4-20Ma/3-15 psi
9	I/P 14M Act. 4-20Ma/6-30 psi
Z	Non-standard

17	SIDE MOUNT POSITIONER
0	None
1	Positioner Ready (no positioner)
A	SMP - P/P Dir/Rev 3-15
B	SMP - P/P Dir/Rev 3-9
C	SMP - P/P Dir/Rev 9-15
D	SMP - I/P Dir/Rev 4-20
E	SMP - I/P Dir/Rev 4-12
F	SMP - I/P Dir/Rev 12-20
G	MK16IQ-S Dir/Rev (w/ HART)
H	MK16IQ-B Dir/Rev
J	MK16IQ-FF Dir/Rev (Foundation Fieldbus)